

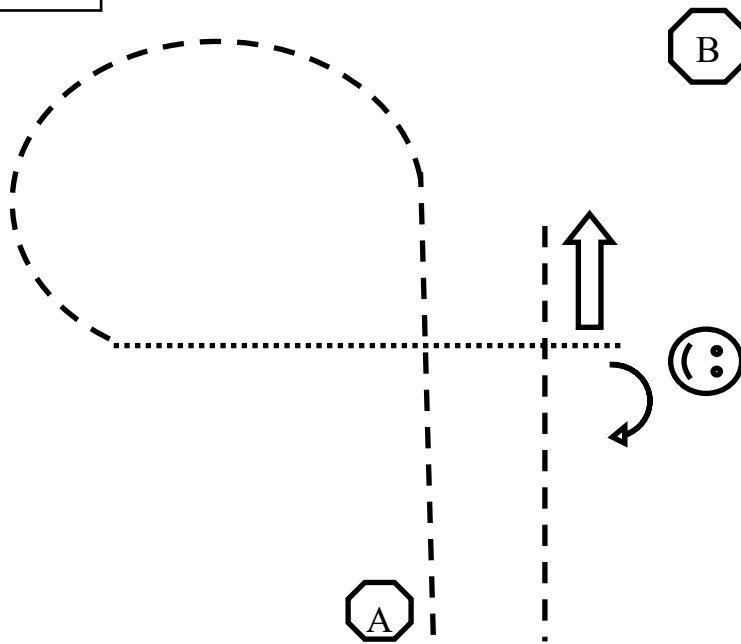

Early Bird Show
Pattern Book
April 5-6, 2025

SHOWMANSHIP

Yth WT 5-10
Yth WT 11-18



1. Trot Straight and approximate 2/3 circle
2. Walk
3. Set Up
4. Inspection
5. 90 turn
6. Back (4-6 Steps)
7. Trot to exit

SHOWMANSHIP

AM WT

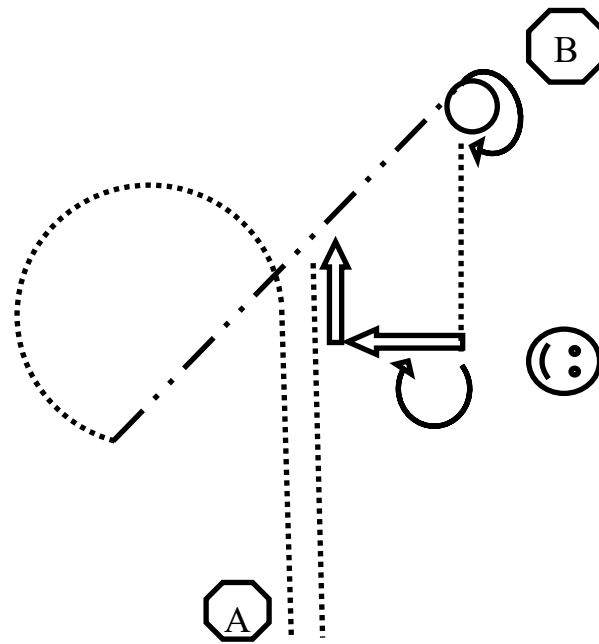

1. Walk Straight and approx. 3/4 loop.
2. Extended Walk (diagonal line) to B
3. 495 (approx.) turn
4. Walk. Stop with Hip at Judge
5. 270 Turn
6. Set up
7. Inspection
8. Back "L", Walk to exit

SHOWMANSHIP

Novice Yth
Novice AM
Yth 13&u

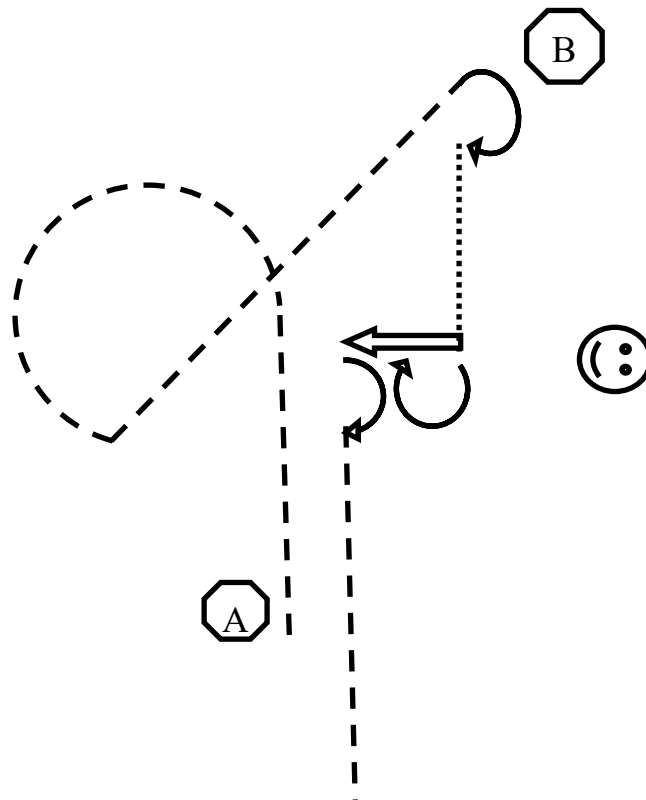

1. Trot Straight and approx. 3/4 loop.
2. Trot (diagonal line) to B
3. 135 degree (approx.) turn
4. Walk. Stop with Hip at Judge
5. 270 Turn
6. Set up
7. Inspection
8. Back (4-6 steps), 90 turn, Trot to exit

SHOWMANSHIP

AM
Yth 18&u
ALL BREED

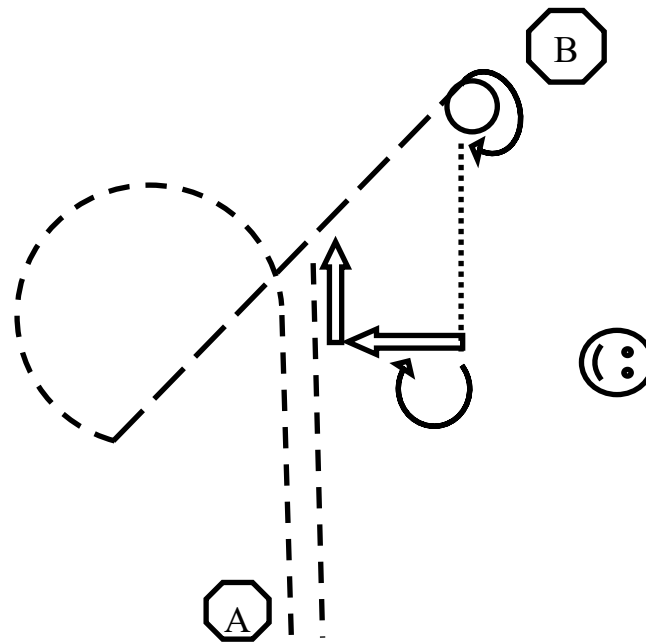

1. Trot Straight and approx. 3/4 loop.
2. Extended Trot (diagonal line) to B
3. 495 degree (approx.) turn
4. Walk. Stop with Hip at Judge
5. 270 Turn
6. Set up
7. Inspection
8. Back "L", Trot to exit

Hunt Seat Equitation

Cone A to be placed on the center line

All Walk Trot

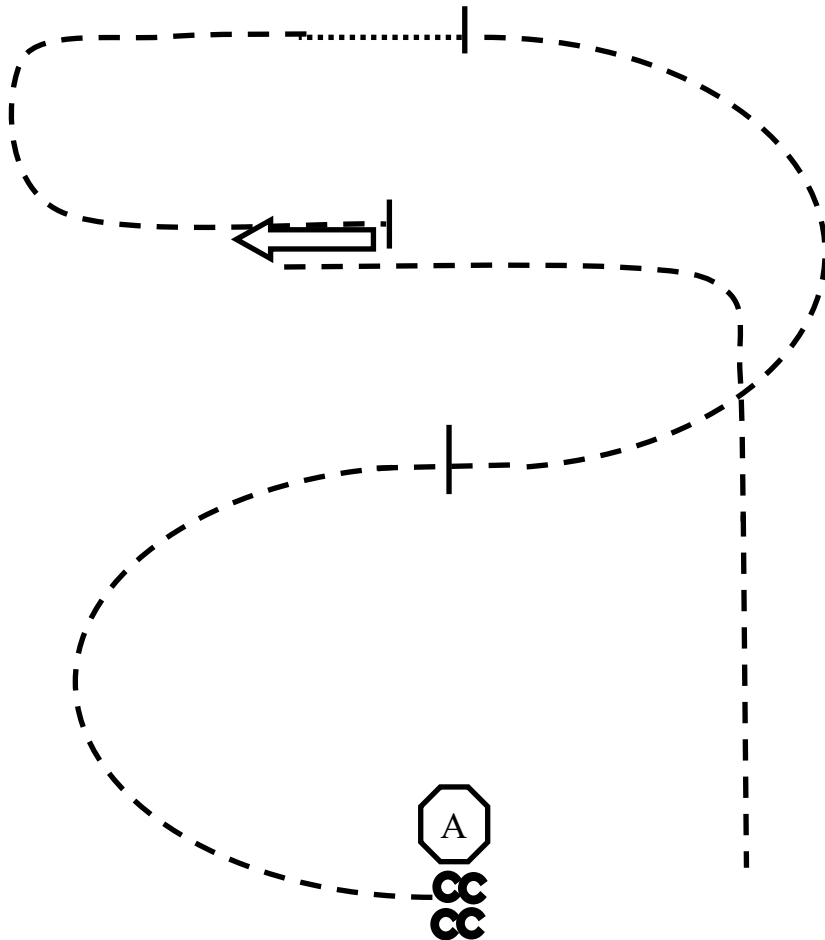

Be ready at A

1. Posting trot (LD)
2. Change Diagonals
3. Posting Trot (RD)
4. Walk (4-6 steps)
5. Sitting Trot
6. Stop and Back
7. Posting Trot (LD)

Hunt Seat Equitation

Novice Yth
Novice AM
Yth 13&u

Cone A to be placed on the center line

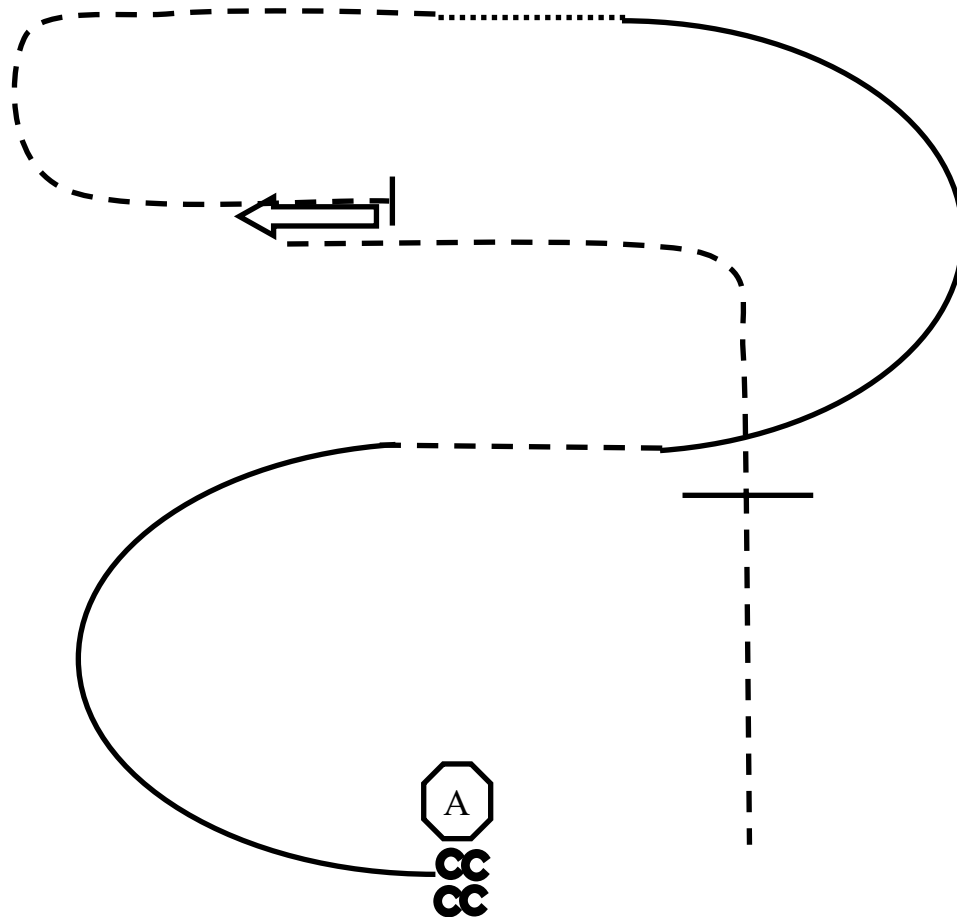

Be ready at A

1. Canter (RL)
2. Sitting trot
3. Canter (LL)
4. Walk (4-6 steps)
5. Posting Trot (RD)
6. Stop and Back
7. Sitting Trot
8. Half way back to A, Posting Trot (LD).

Hunt Seat Equitation

AM
Yth 18&u
ALL BREED

Cone A to be placed on the center line

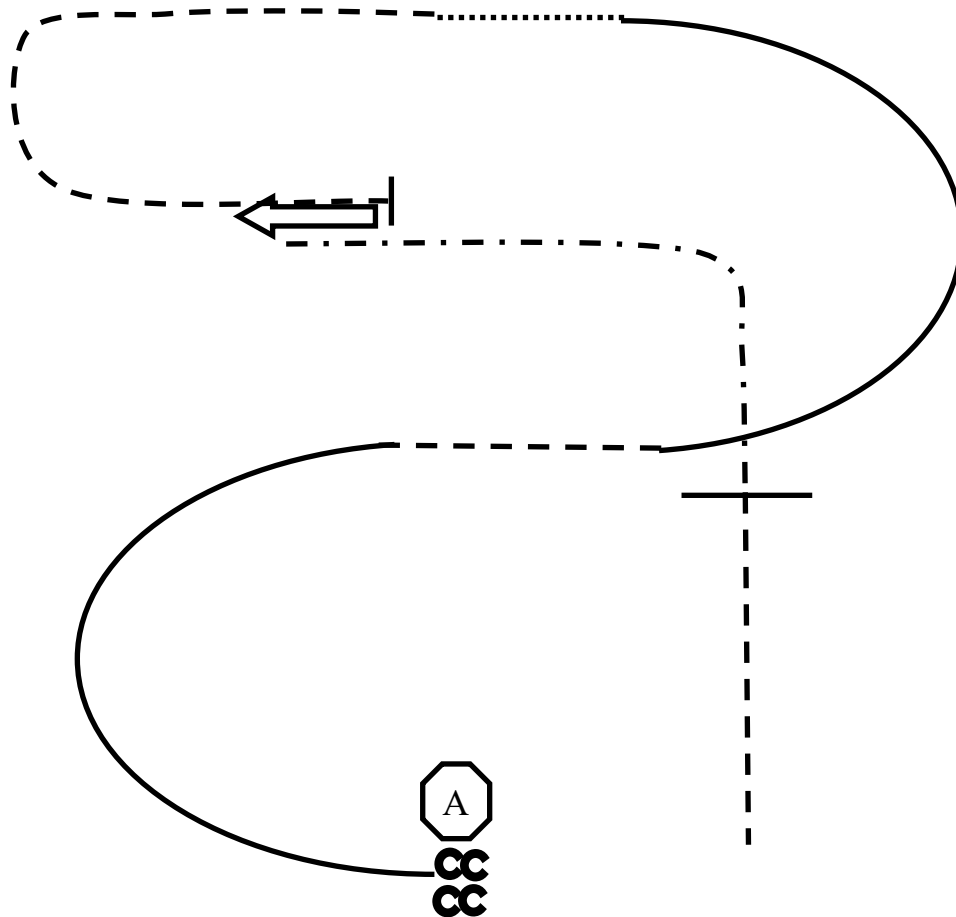

Be ready at A

1. Canter (RL)
2. Sitting trot
3. Canter (LL)
4. Walk (4-6 steps)
5. Posting Trot (RD)
6. Stop and Back
7. Establish trot, then get into 2 point around corner
8. Half way back to A, Posting Trot (LD).

Trail

In Hand

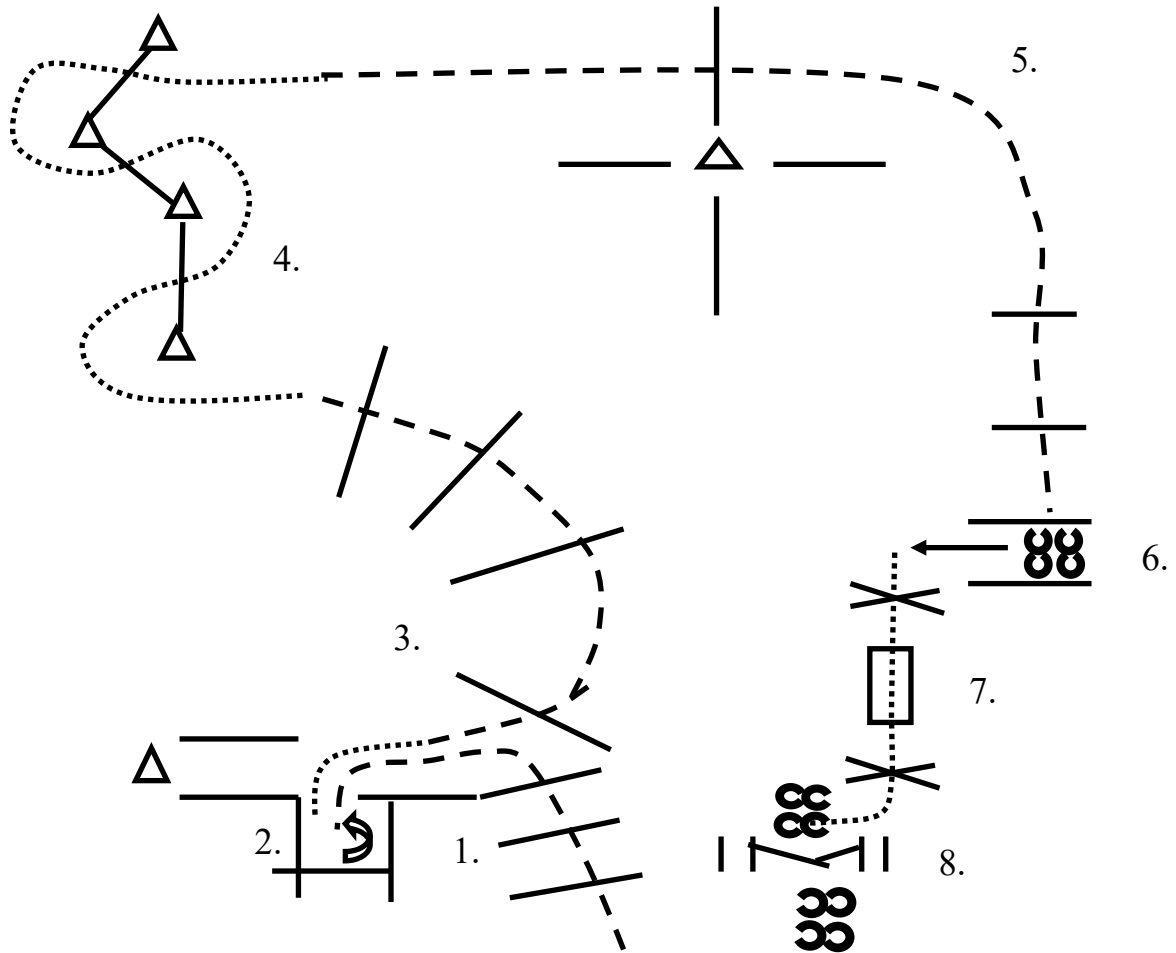

1. Trot poles into box
2. 180 either way
3. Walk out of box, then trot over 4 poles
4. Walk Serpentine
5. Trot over poles.
6. Stop between poles, sidepass RIGHT
7. Walk pole, bridge, pole
8. Work gate (LEFT Hand)

Trail

All Walk Trot

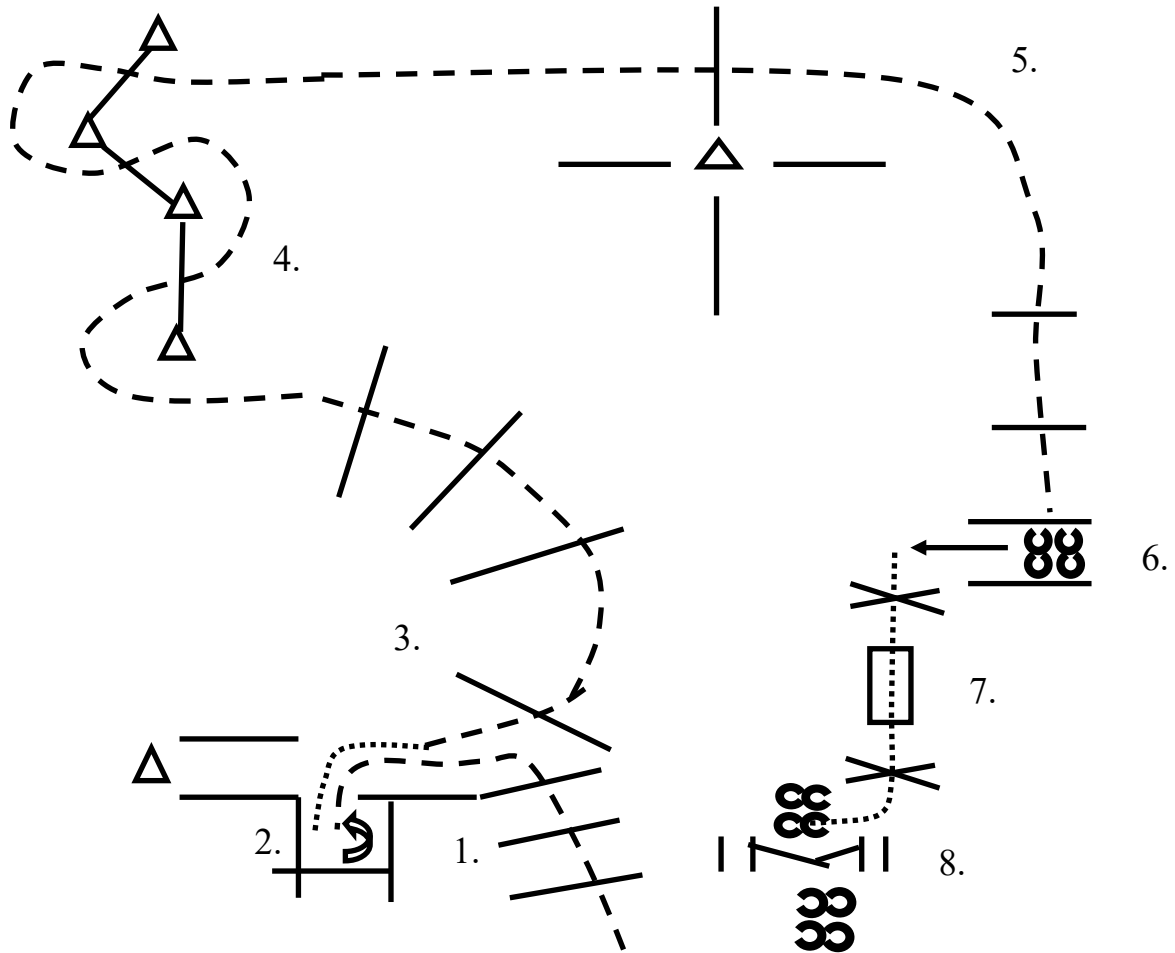

1. Trot poles into box
2. 180 either way
3. Walk out of box, then trot over 4 poles
4. Trot Serpentine
5. Trot over poles.
6. Stop between poles, sidepass RIGHT
7. Walk pole, bridge, pole
8. Work gate (LEFT Hand)

Trail

Novice Youth
Novice Amateur
Green
ALL BREED

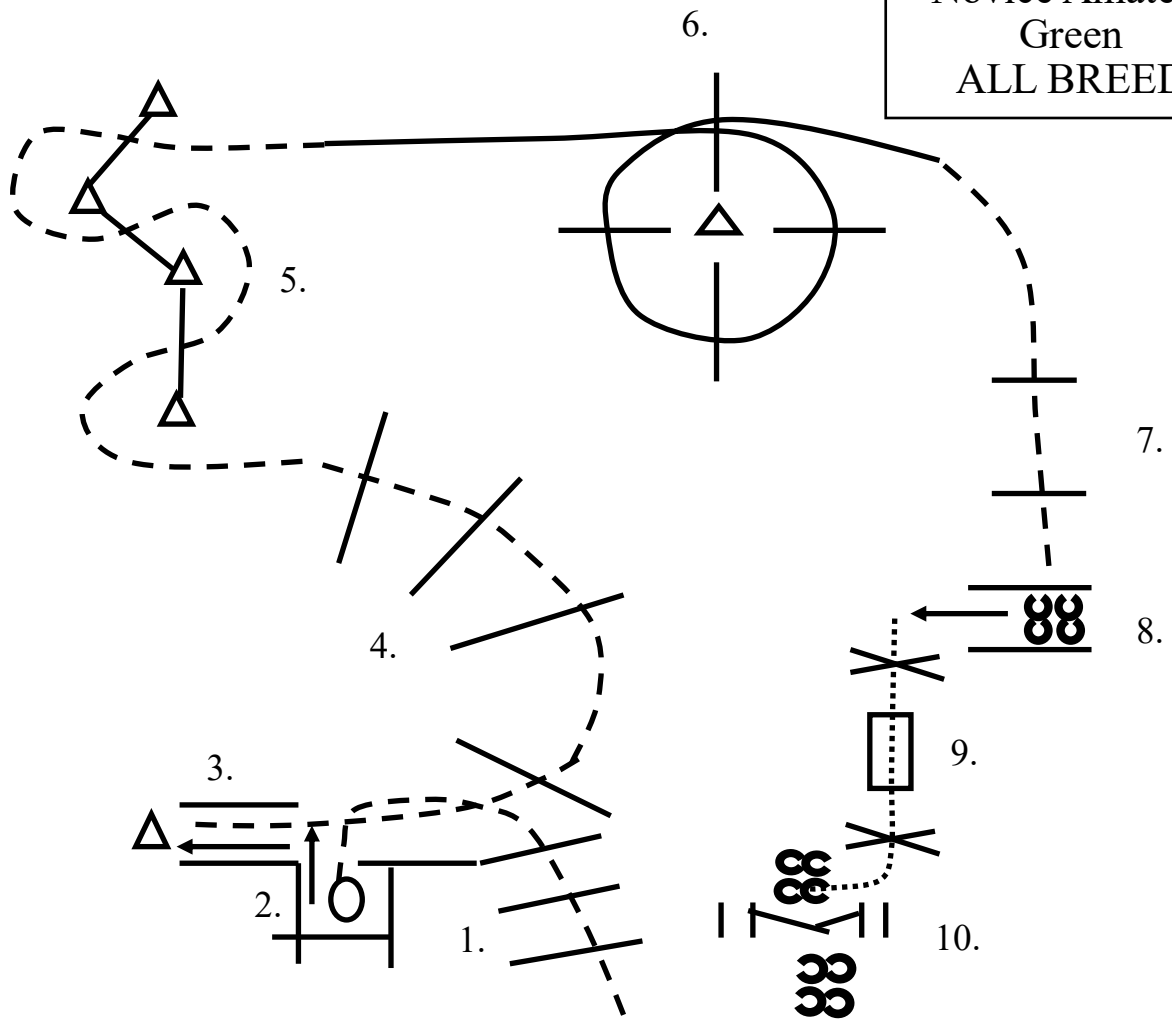

1. Trot poles into box
2. 360 either way
3. Back out box into chute
4. Trot over 4 poles
5. Trot Serpentine
6. Lope (RL) poles
7. Trot over poles.
8. Stop between poles, sidepass RIGHT
9. Walk pole, bridge, pole
10. Work gate (LEFT Hand)

Trail

AM
Yth 18&u
Open

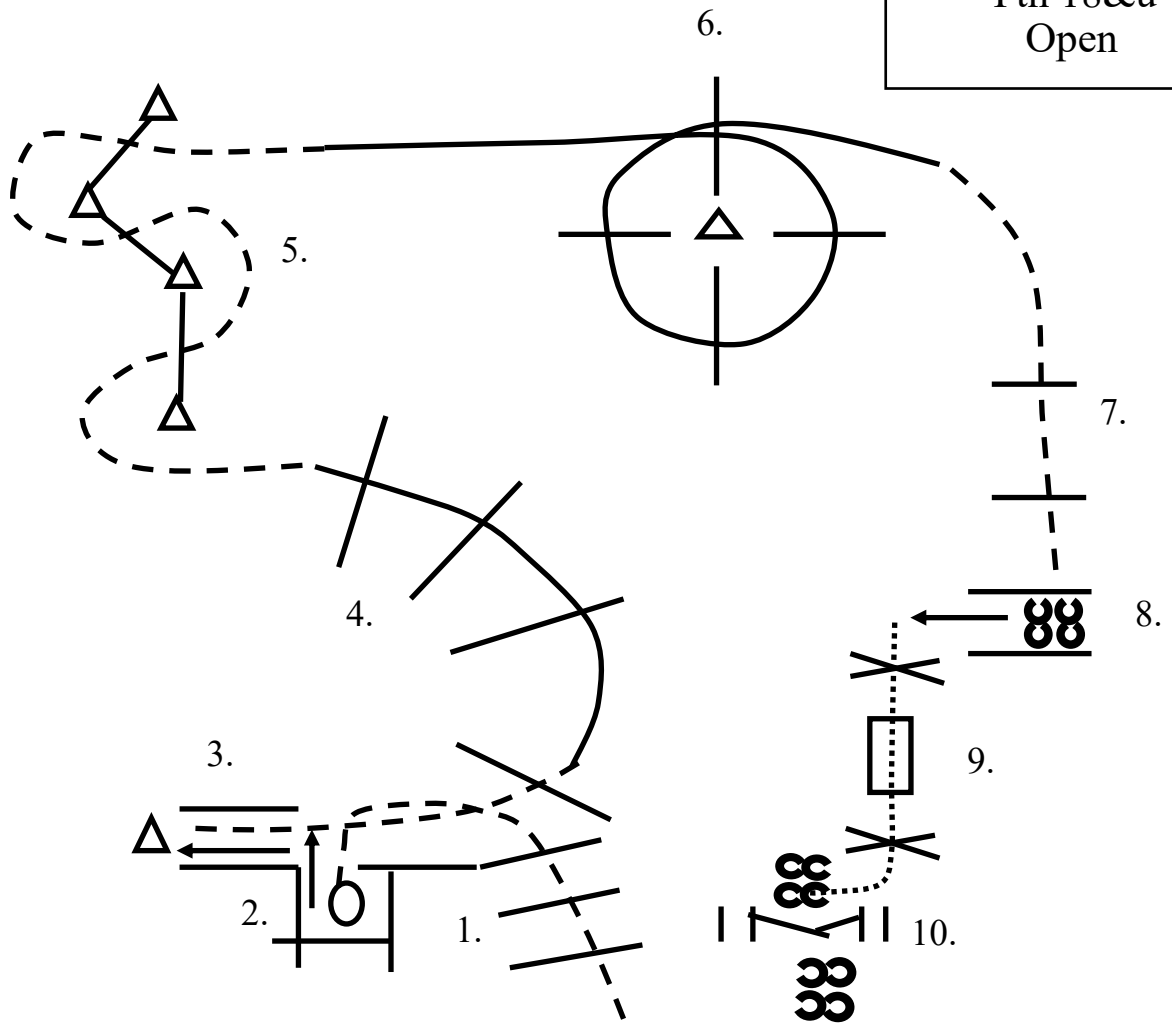

1. Trot poles into box
2. 360 either way
3. Back out box into chute
4. Trot over 1 pole, then Lope (LL) over 3 poles
5. Trot Serpentine
6. Lope (RL) poles
7. Trot over poles.
8. Stop between poles, sidepass RIGHT
9. Walk pole, bridge, pole
10. Work gate (LEFT Hand)

30 poles
Gate
6 cones
bridge

HORSEMANSHIP

Cone A to be placed 10 foot off the rail.

All Walk Trot

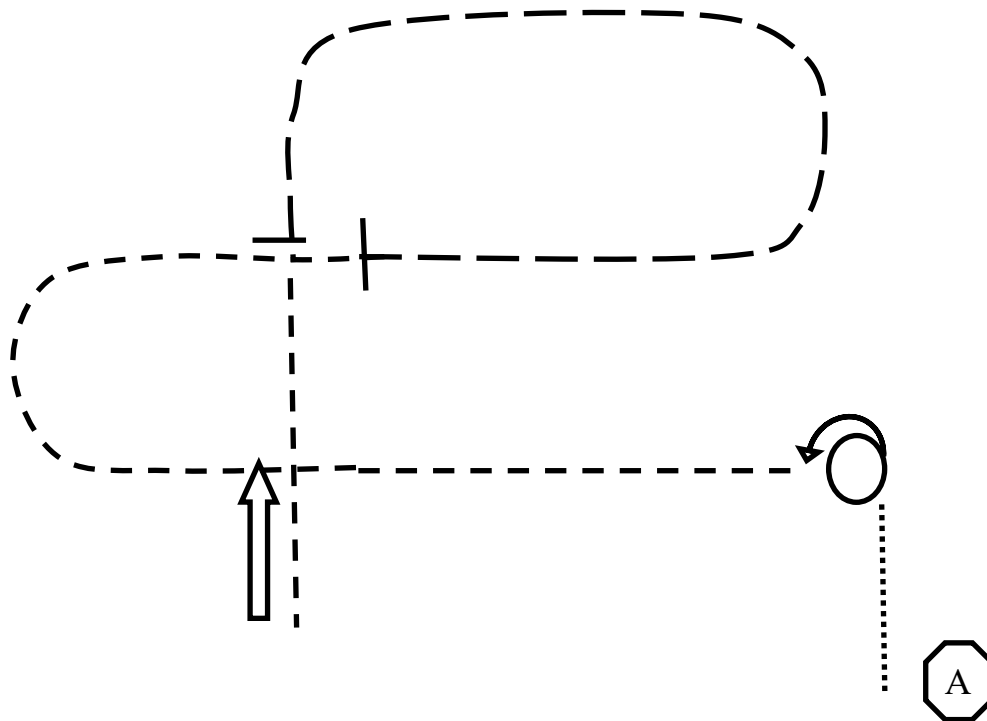

1. Walk (2 Horse Lengths)
2. 1 1/4 turn LEFT
3. Jog Loop
4. Extended Jog (as shown).
5. Approx. halfway back to A, slow jog.
6. Even with A, Stop and Back (4-6 steps)

HORSEMANSHIP

Cone A to be placed 10 foot off the rail.

Novice Yth
Novice AM
Yth 13&u

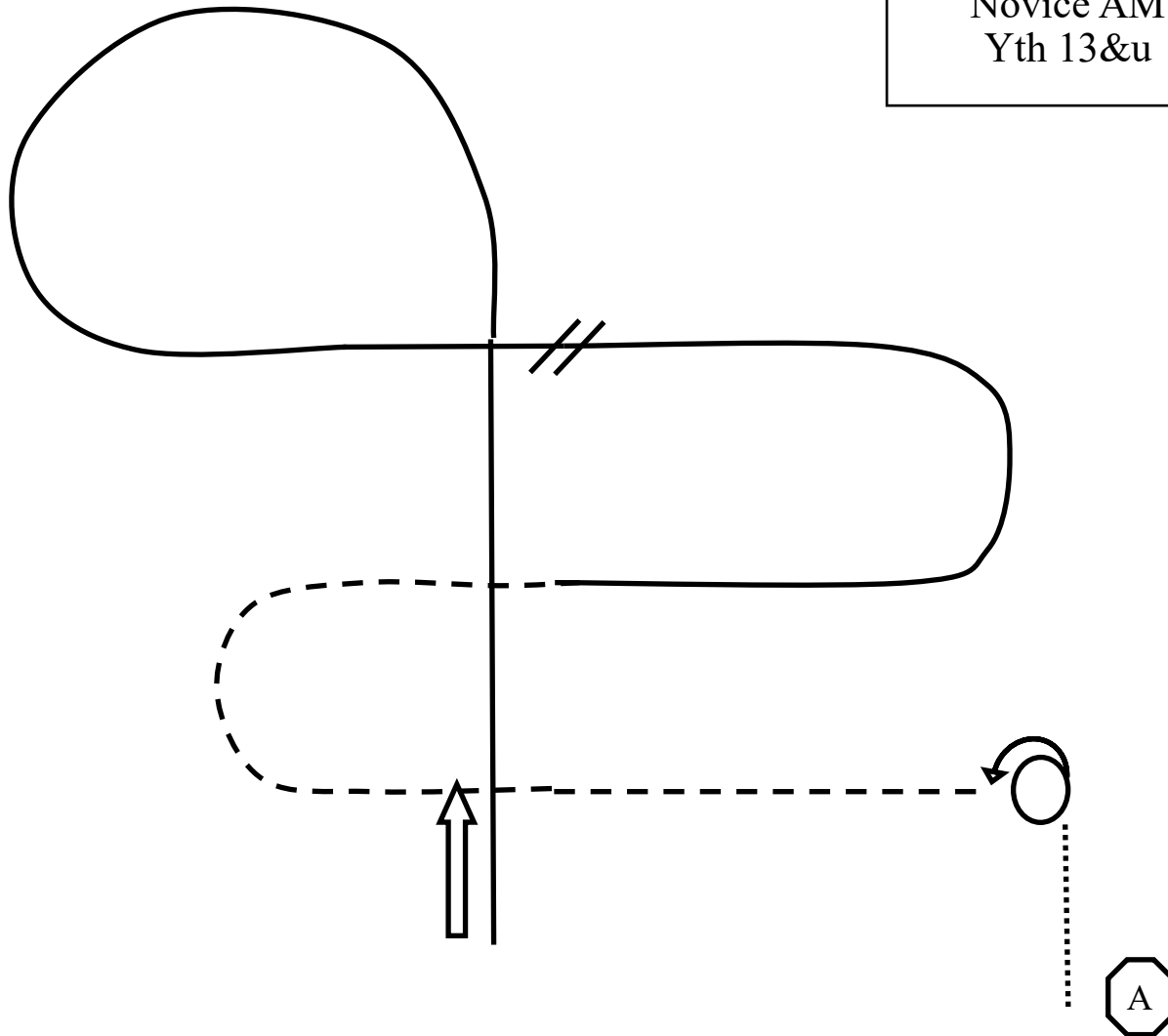

1. Walk (2 Horse Lengths)
2. 1 1/4 turn LEFT
3. Jog Loop
4. Lope (LL) Loop
5. Change Leads
6. Lope (RL) 3/4 circle (approx.) and back even with A.
7. Stop and Back (4-6 steps)

HORSEMANSHIP

Cone A to be placed 10 foot off the rail.

AM
Yth 18&u
ALL BREED

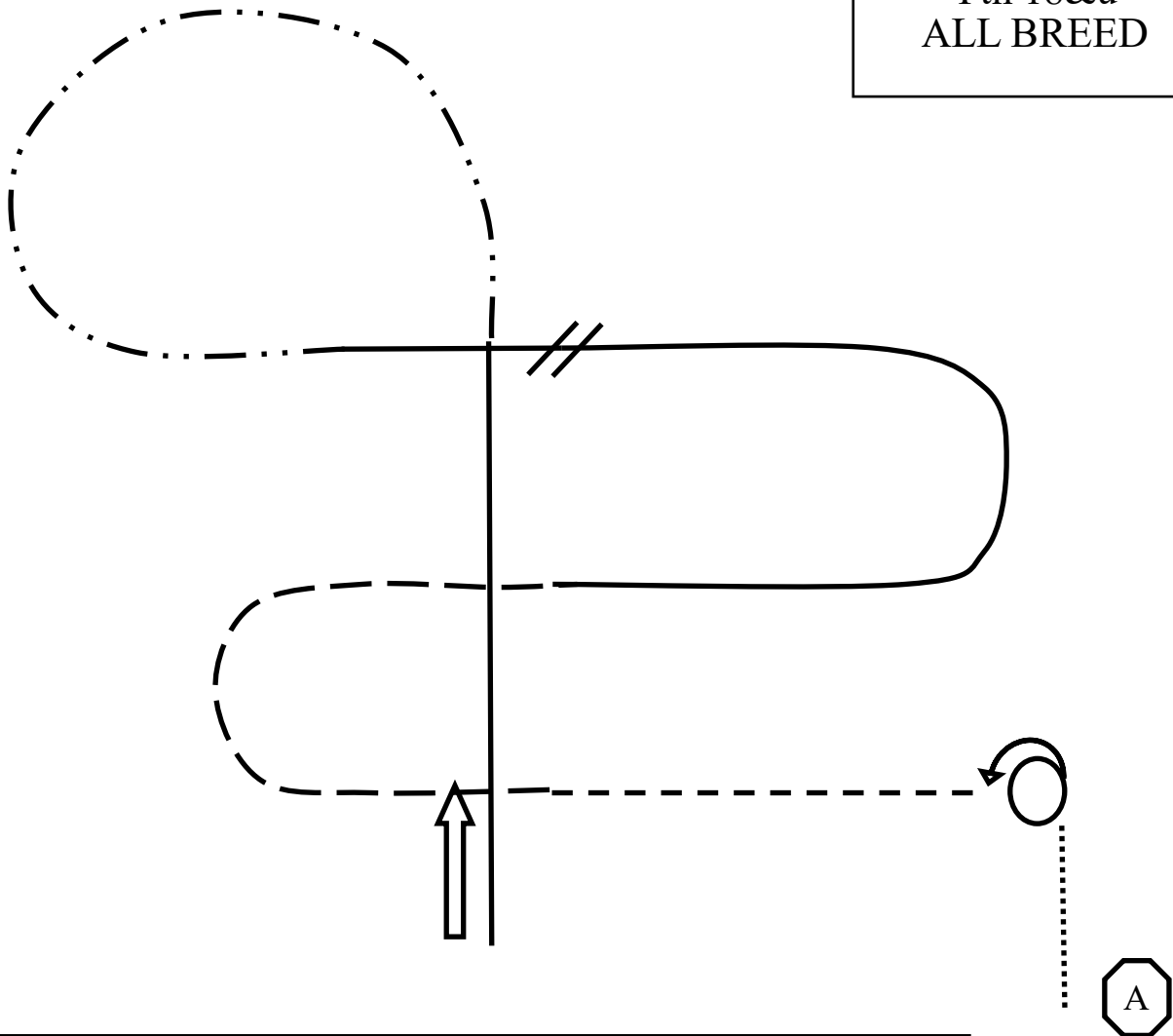

1. Walk (2 Horse Lengths)
2. 1 1/4 turn LEFT
3. Jog to Center
4. Extended Jog Loop
5. Lope (LL) Loop
6. Change Leads
7. Build into extended Lope (RL) 3/4 circle (approx.)
8. Crossing Lope Line, Slow Lope
9. Stop and Back (4-6 steps)

Western Riding

Green Western Riding Pattern #9

Green
Novice AM

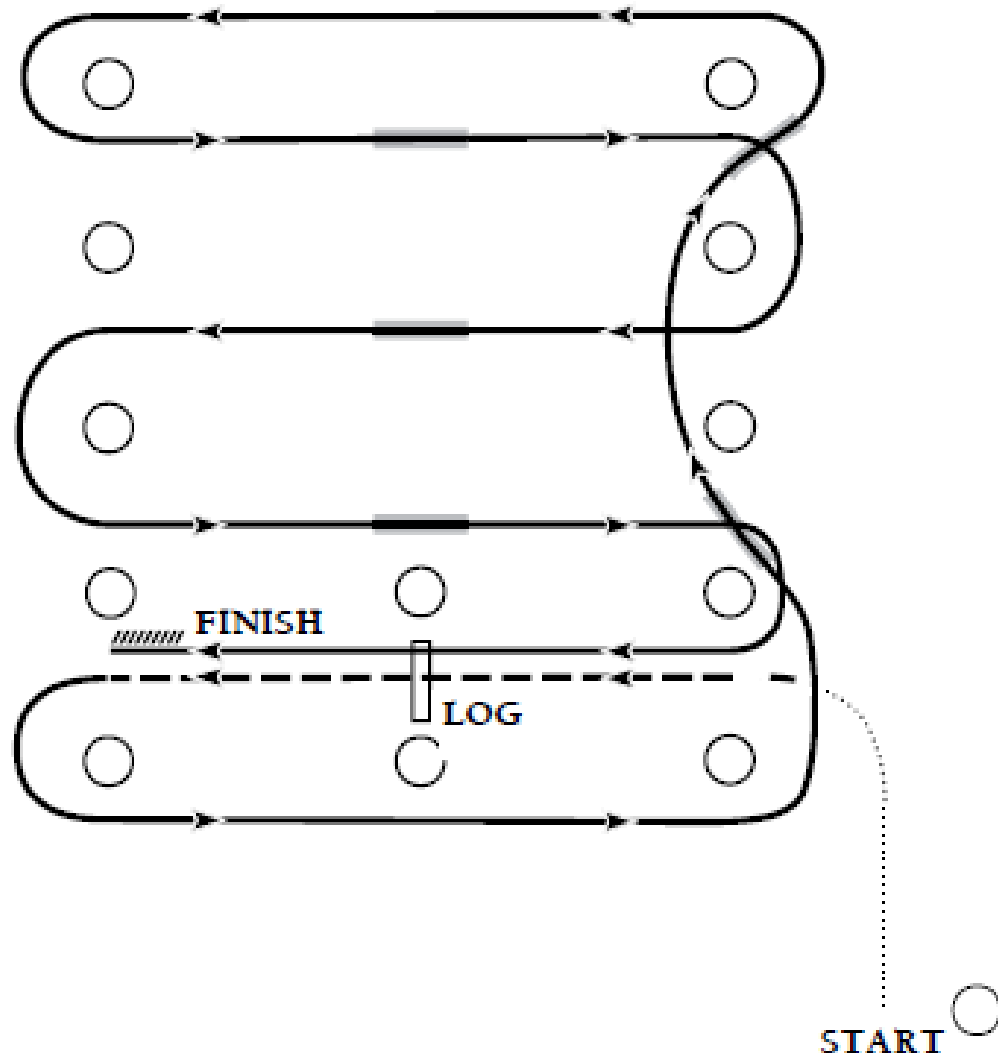

1. Walk at least 15 feet from start cone to the first marker, as drawn, transition to jog, jog over log.
2. Transition to left lead and lope around end.
3. First line change.
4. Second line change, lope around end of arena.
5. First crossing change.
6. Second crossing change.
7. Third crossing change.
8. Lope over log.
9. Lope, stop and back.

Western Riding

Western Riding Pattern #9

Open
Yth
AM
ALL BREED

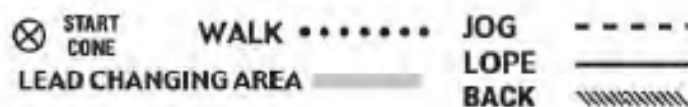
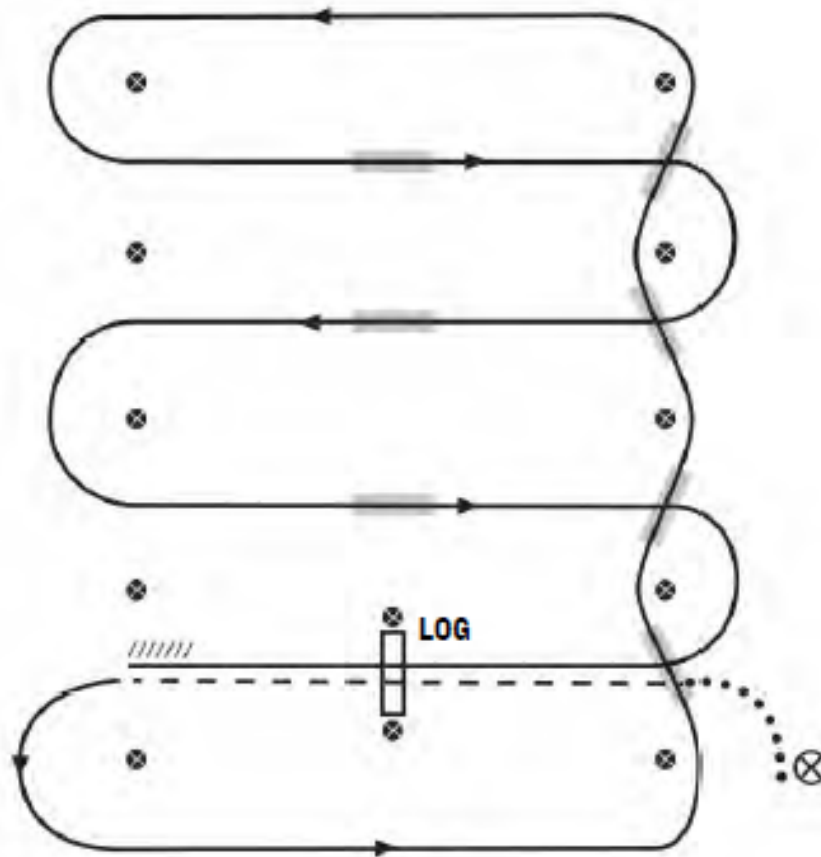

1. Walk at least 15 feet from start cone to the first marker, as drawn, transition to jog, jog over log.
2. Transition to the lope, on the left lead
3. First line change
4. Second line change
5. Third line change
6. Fourth line change
7. First crossing change
8. Second crossing change
9. Third crossing change
10. Lope over log
11. Lope, stop & back