



Fun-  
in  
the Sun

# PATTERN BOOK

July 21-22, 2018

8AM each day



## Judges

Saturday 7/21: Kimberly Garrett

Jennifer Goss

Sunday 7/22:

Meri McKillips-LeMay

Cindy Mergaert

# Iowa Paint Horse Show

Showmanship ( Walk/Trot \*AM Will Walk 13&Under Youth)

Show Date:

w w w . H o r s e S h o w P a t t e r n s . c o m

w w w . H o r s e S h o w P a t t e r n s . c o m

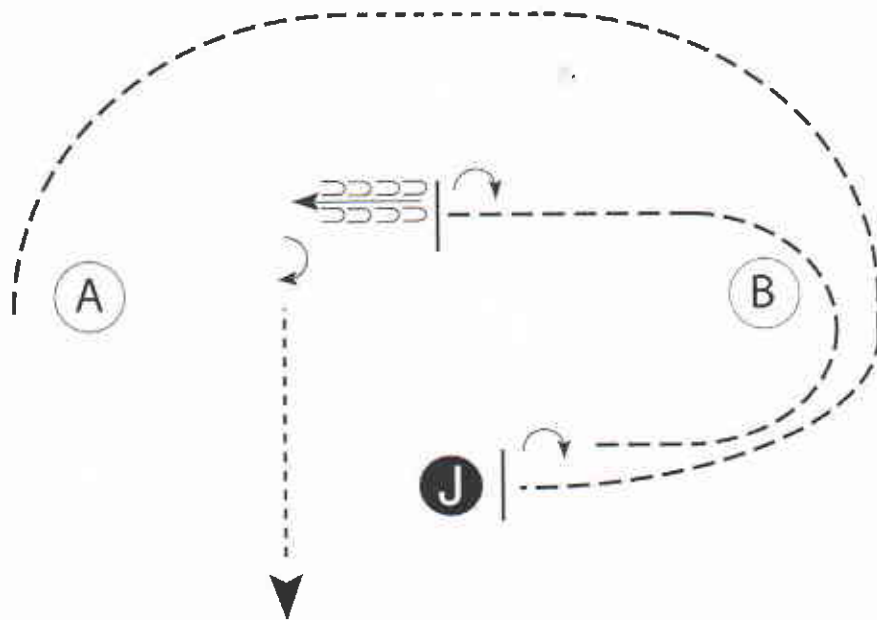

Be ready at A.

1. Trot an arc to the right.
2. At the top of the arc, walk two strides.
3. Trot in a half circle and straight to Judge.
4. Stop and set up for inspection.
5. When dismissed, perform a 1/2 turn.
6. Trot around B as shown. When even with Judge, stop and perform a 1/2 turn.
7. Back approximately one horse length.
8. Perform 1/4 turn and walk straight away to exit.

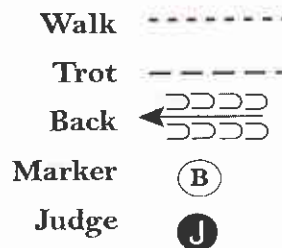

Follow the instructions of your ring steward.

[S/2-46]

Pattern Provided by:  
*Kimberly Garrett*

# Iowa Paint Horse Show

## Showmanship ( 18 & under Youth & Amateur)

Show Date: and all Novice

w w w . H o r s e S h o w P a t t e r n s . c o m

w w w . H o r s e S h o w P a t t e r n s . c o m

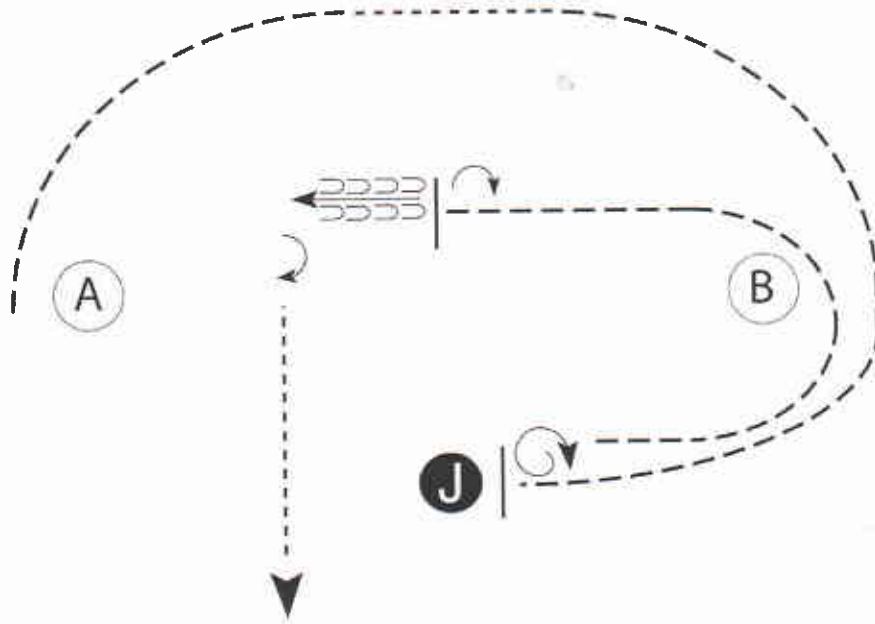

Be ready at A.

1. Trot an arc to the right.
2. At the top of the arc, walk two strides.
3. Trot in a half circle and straight to Judge.
4. Stop and set up for inspection.
5. When dismissed, perform a 1 1/2 turn.
6. Trot around B as shown. When even with Judge, stop and perform a 1/2 turn.
7. Back approximately one horse length.
8. Turn 1/4 turn and walk straight away to exit.

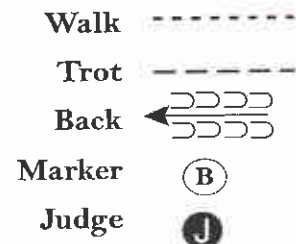

Follow the instructions of your ring steward.

[S/3-46]

Pattern Provided by:  
*Kimberly Garrett*

# Iowa Paint Horse Show

## Hunt Seat Equitation ( WALK/TROT Youth & Amateur)

Show Date:

www.HorseShowPatterns.com

www.HorseShowPatterns.com

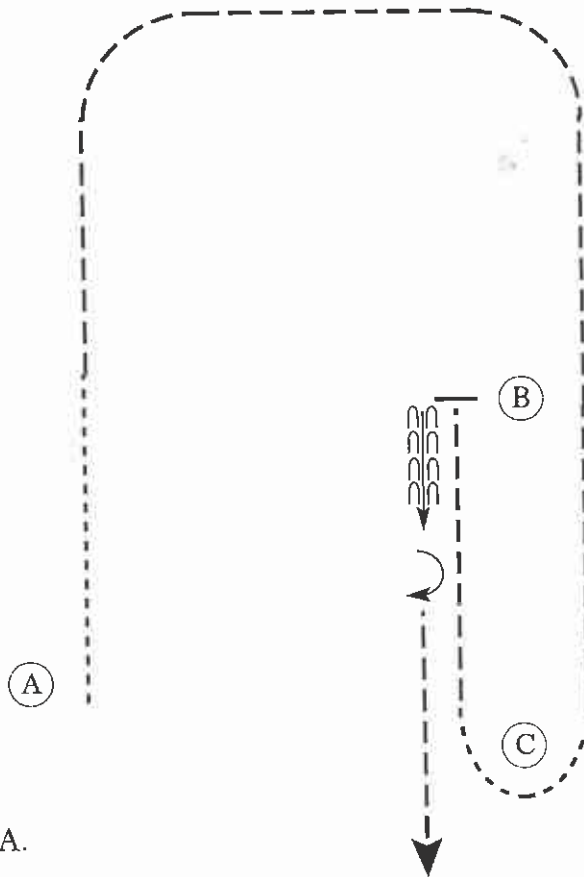

Be ready at A.

1. Walk until even with B.
2. Trot on the left diagonal to B.
3. Sitting trot from B to C.
4. Walk around C.
5. Trot on the right diagonal to B.
6. Stop and back approximately one horse length.
7. Perform a 180 degree turn to the right on the hindquarters and trot to exit.

Walk	.....
Trot	-----
Extended Trot	-----
Canter	—————
Leg Yield	
Lead Change	///
Back	←←←←
Marker	(B)
Sidepass	←-----
Hand Gallop	—————

[HSE/WT-38]

Pattern Provided by:  
*Kimberly Garrett*

# Iowa Paint Horse Show

Hunt Seat Equitation (13& under & Novice Youth & Am)

Show Date:

www.HorseShowPatterns.com

www.HorseShowPatterns.com

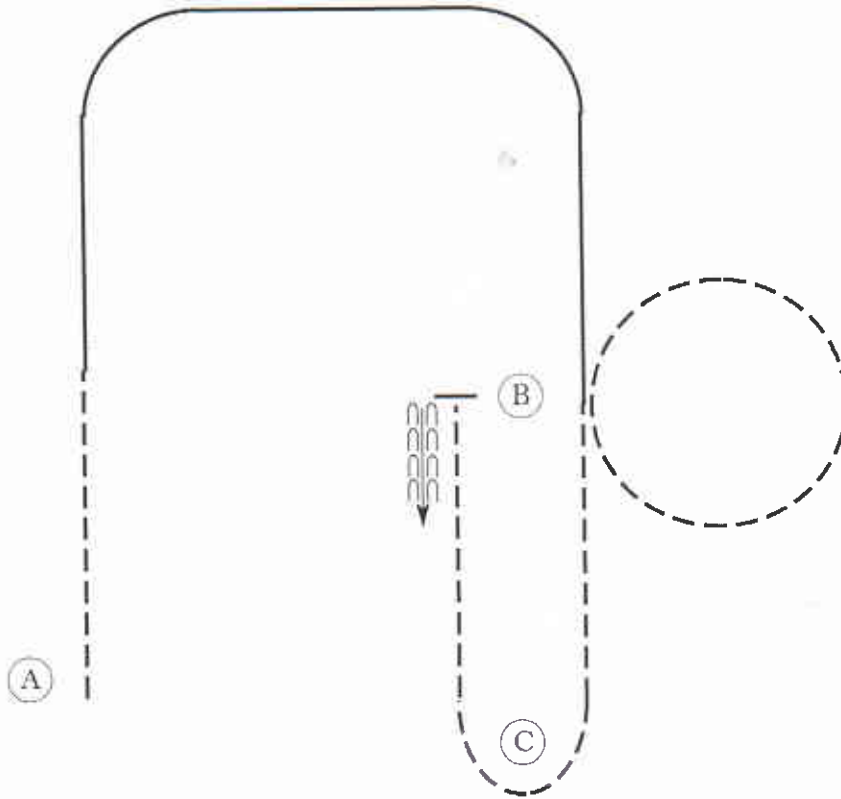

Be ready at A.

1. Trot on the left diagonal.
2. Canter on the right lead to B.
3. Trot a circle to the left on the correct diagonal.
4. Sitting trot to and around C.
5. Trot on the left diagonal to B.
6. Stop and back.

Walk	-----
Trot	- - - - -
Extended Trot	—————
Canter	—————
Leg Yield	
Lead Change	↘
Back	←←←←←
Marker	⊙ B
Sidepass	←→
Hand Gallop	—————

[HSE/1-77]

Pattern Provided by:  
*Kimberly Garrett*

# Iowa Paint Horse Show

## Hunt Seat Equitation (18&under Youth and Amateur)

Show Date:

www.HorseShowPatterns.com

www.HorseShowPatterns.com

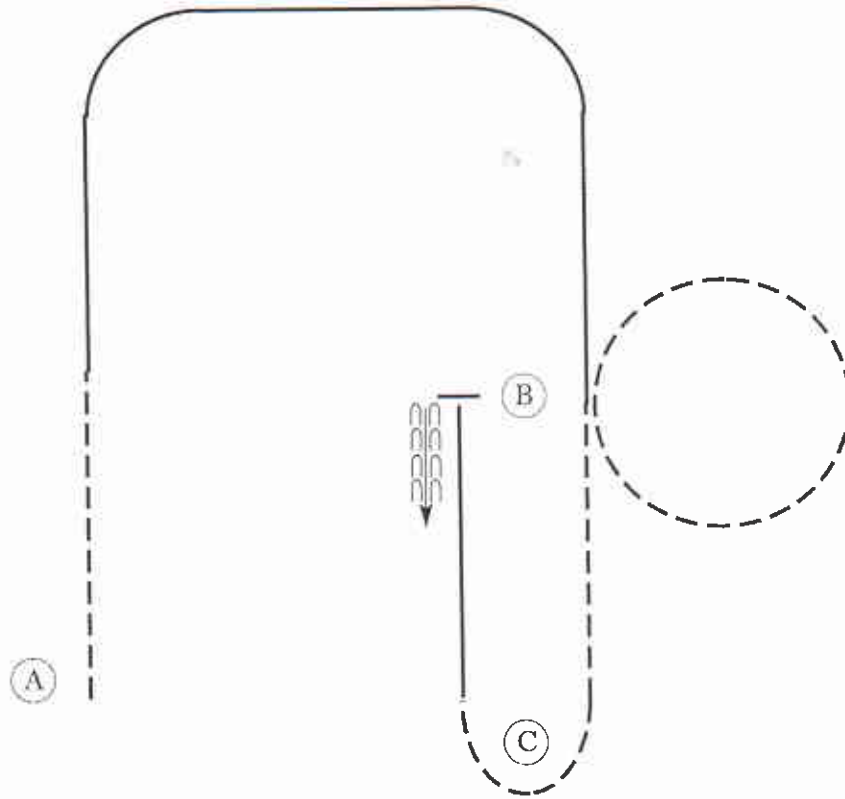

Be ready at A.

1. Trot on the left diagonal.
2. Canter on the right lead to B.
3. Trot a circle to the left on the correct diagonal.
4. Sitting trot to and around C.
5. Canter left lead to B.
6. Stop and back.

Walk	-----
Trot	- - - - -
Extended Trot	—————
Canter	—————
Leg Yield	
Lead Change	—/—
Back	←←←←←
Marker	⊙ B
Sidepass	←←←←←
Hand Gallop	—————

[HSE/2-77]

Pattern Provided by:  
*Kimberly Garrett*

# Iowa Paint Horse Show

Western Horsemanship ( WALK/TROT Youth & Amateur)

Show Date:

w w w . H o r s e S h o w P a t t e r n s . c o m

w w w . H o r s e S h o w P a t t e r n s . c o m

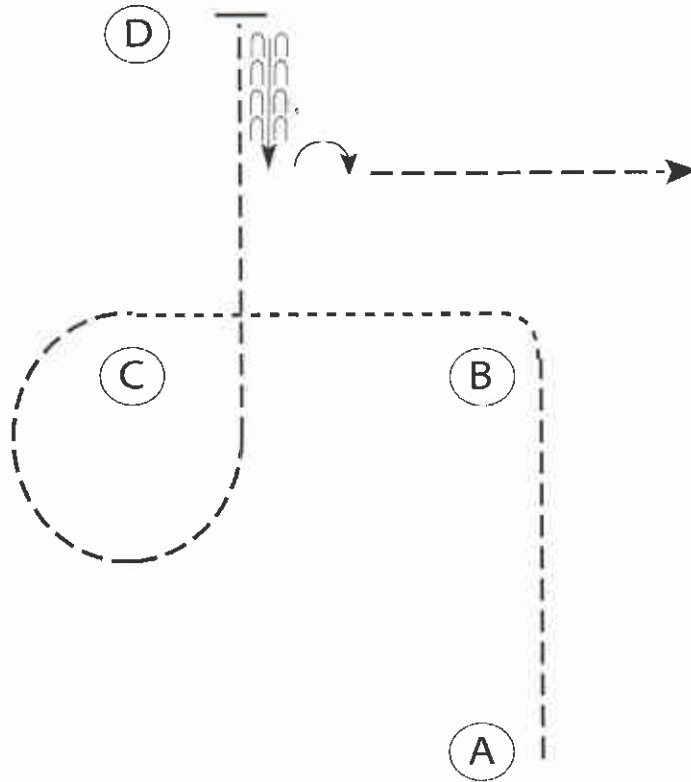

Be ready at A.

1. Jog to B.
2. Walk around B to the left and to C.
3. Jog at C around to D.
4. Stop and D and back approximately one horse length.
5. Turn 90 degrees to the right on the hindquarters and jog out.

Follow the directions of your ring steward.

Walk	.....
Jog	-----
Extended Jog	- - - - -
Lope	—————
Lead Change	///
Back	←←←←←
Marker	(B)

[WH/WT-78]

Pattern Provided by:  
*Kimberly Garrett*

# Iowa Paint Horse Show

## Western Horsemanship ( All Novice 13 & Under Youth)

Show Date:

w w w . H o r s e S h o w P a t t e r n s . c o m

w w w . H o r s e S h o w P a t t e r n s . c o m

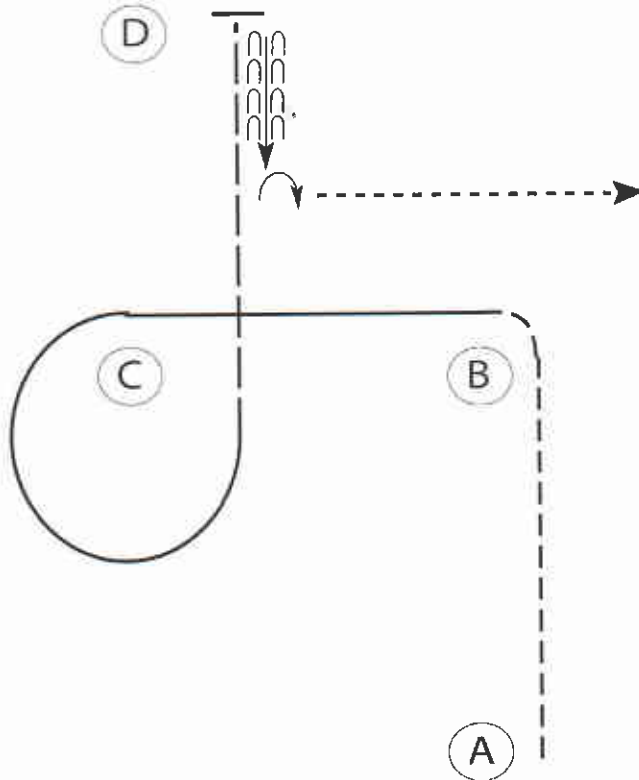

Be ready at A.

1. Jog to and around B.
2. Lope on the left lead from B to and around C.
3. Extended jog from C to D.
4. Stop at D and back approximately one horse length.
5. Turn 90 degrees to the right on the hindquarters and walk out.

Follow the directions of your ring steward.

Walk	.....
Jog	-----
Extended Jog	-----
Lope	-----
Lead Change	-----
Back	←-----
Marker	⊙ B

[WH/2-78]

Pattern Provided by:  
*Kimberly Garrett*



# Iowa Paint Horse Show

Western Horsemanship ( 18 & under Youth & Amateur)

Show Date:

w w w . H o r s e S h o w P a t t e r n s . c o m

w w w . H o r s e S h o w P a t t e r n s . c o m

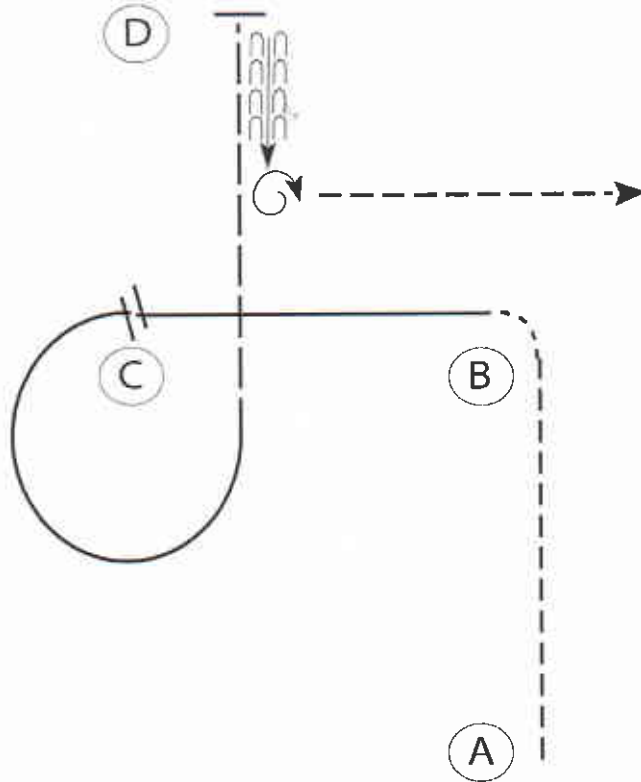

Be ready at A.

1. Jog to B.
2. Walk around B.
3. Lope on the right lead from B to C.
4. Perform a simple lead change at C.
5. Lope on the left lead around C.
6. Extended jog from C to D.
7. Stop at D and back approximately one horse length.
8. Spin 1 1/4 turns to the right on the hindquarters and jog out.

- Walk
- Jog
- Extended Jog
- Lope
- Lead Change
- Back
- Marker

Follow the directions of your ring steward.

[WH/3-78]

Pattern Provided by:  
*Kimberly Garrett*



## Western Riding Pattern #5

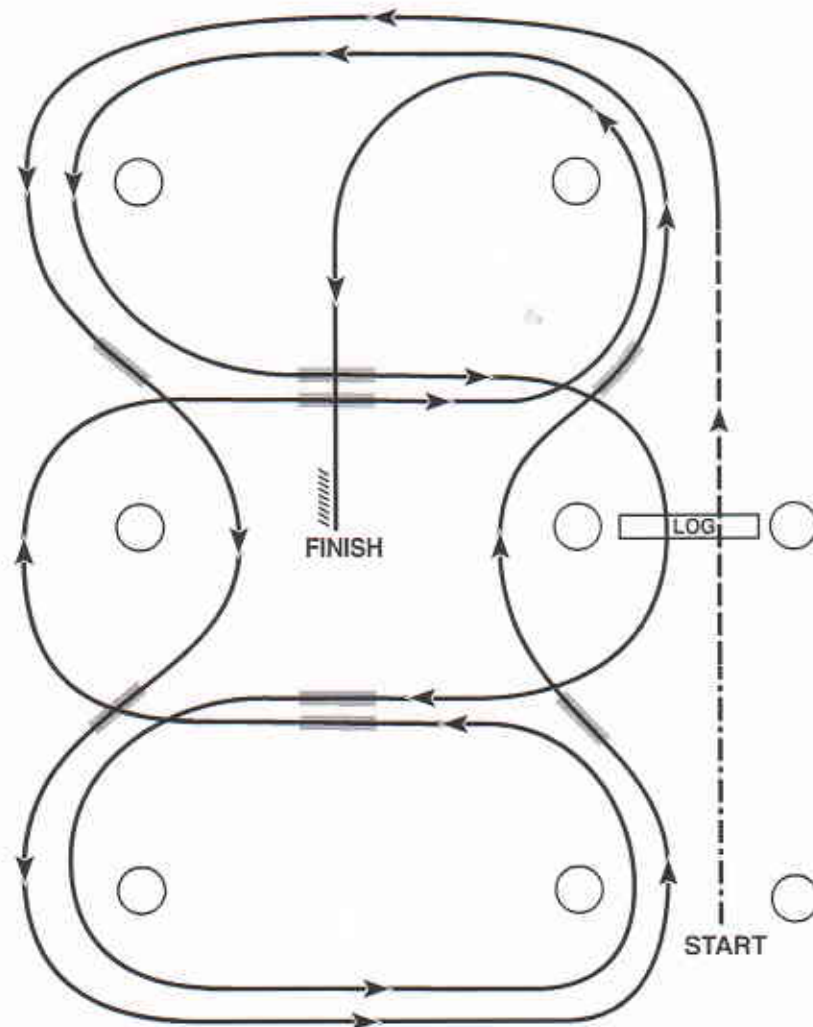

Recommended for small arenas.

1. Walk, transition to jog, jog over log.
2. Transition to the lope, on the left lead.
3. First line change.
4. Second line change.
5. Third line change.
6. Fourth line change.
7. First crossing change.
8. Lope over log.
9. Second crossing change.
10. Third crossing change.
11. Fourth crossing change.
12. Lope, stop and back.

# IOWA PAINT HORSE CLUB

July 21st

All Walk Trot/In hand

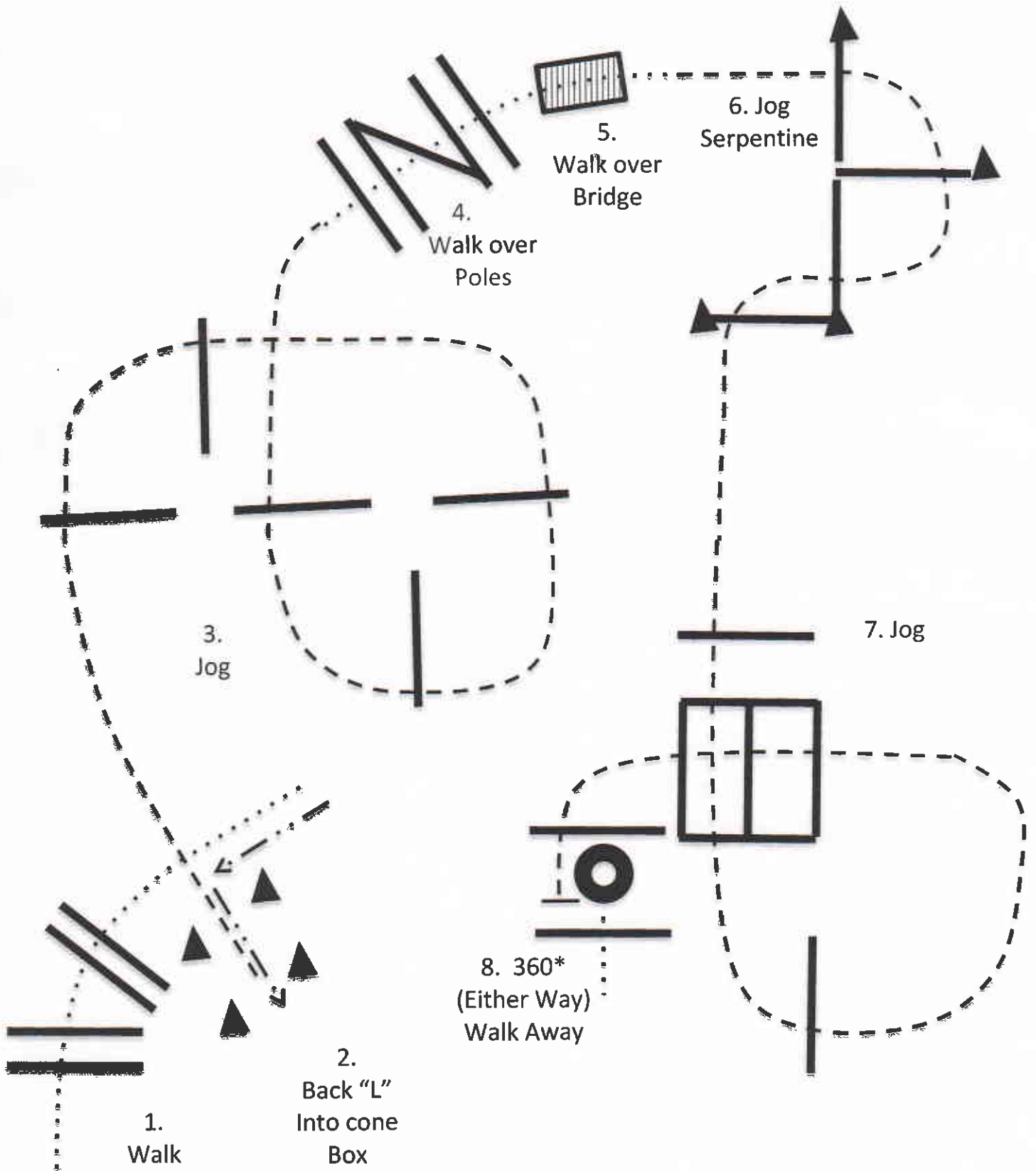

# IOWA PAINT HORSE CLUB

July 21st

All Trail

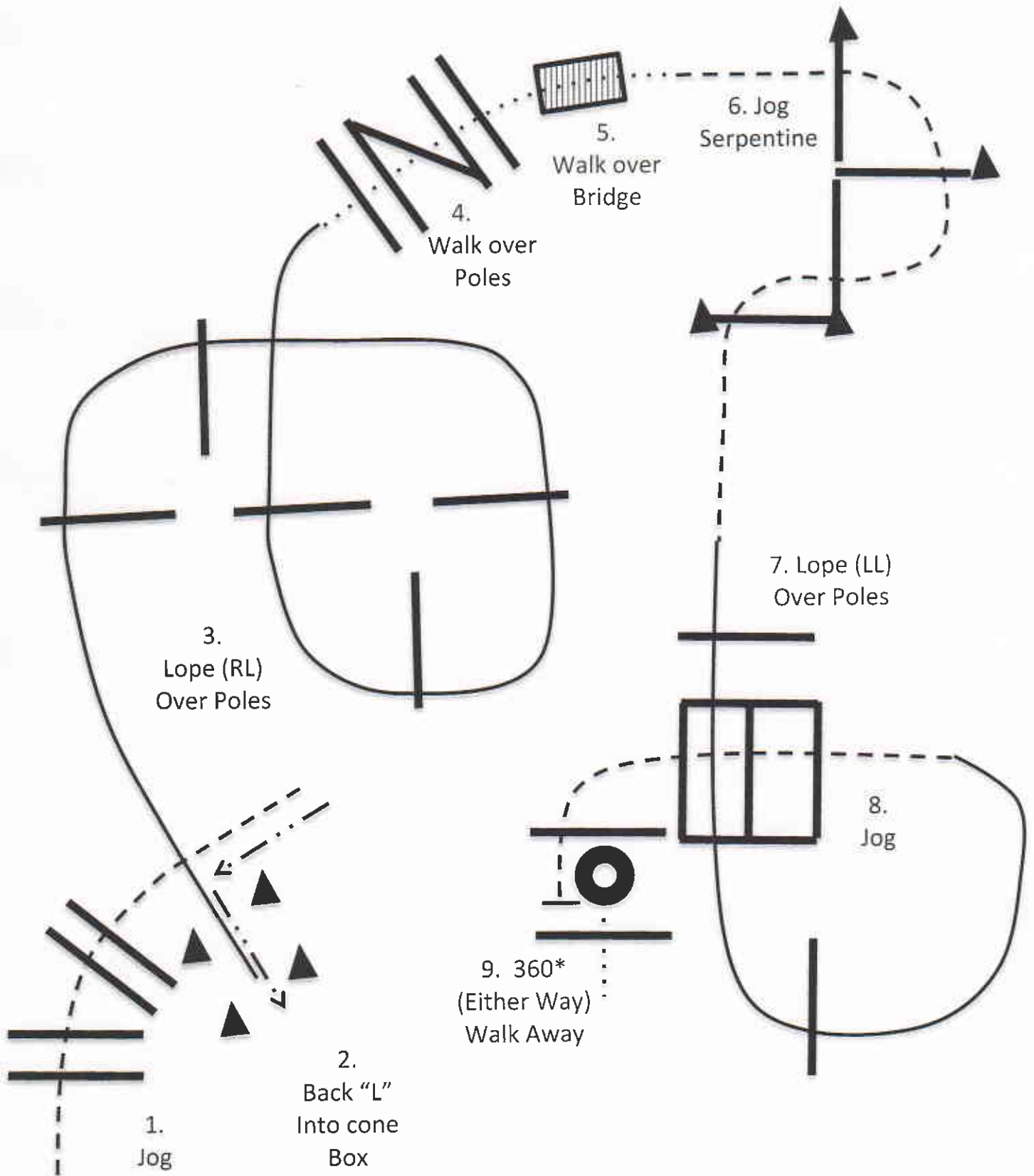

# Iowa Paint Horse Show

## Ranch Riding (All classes)

Show Date:

www.HorseShowPatterns.com

www.HorseShowPatterns.com

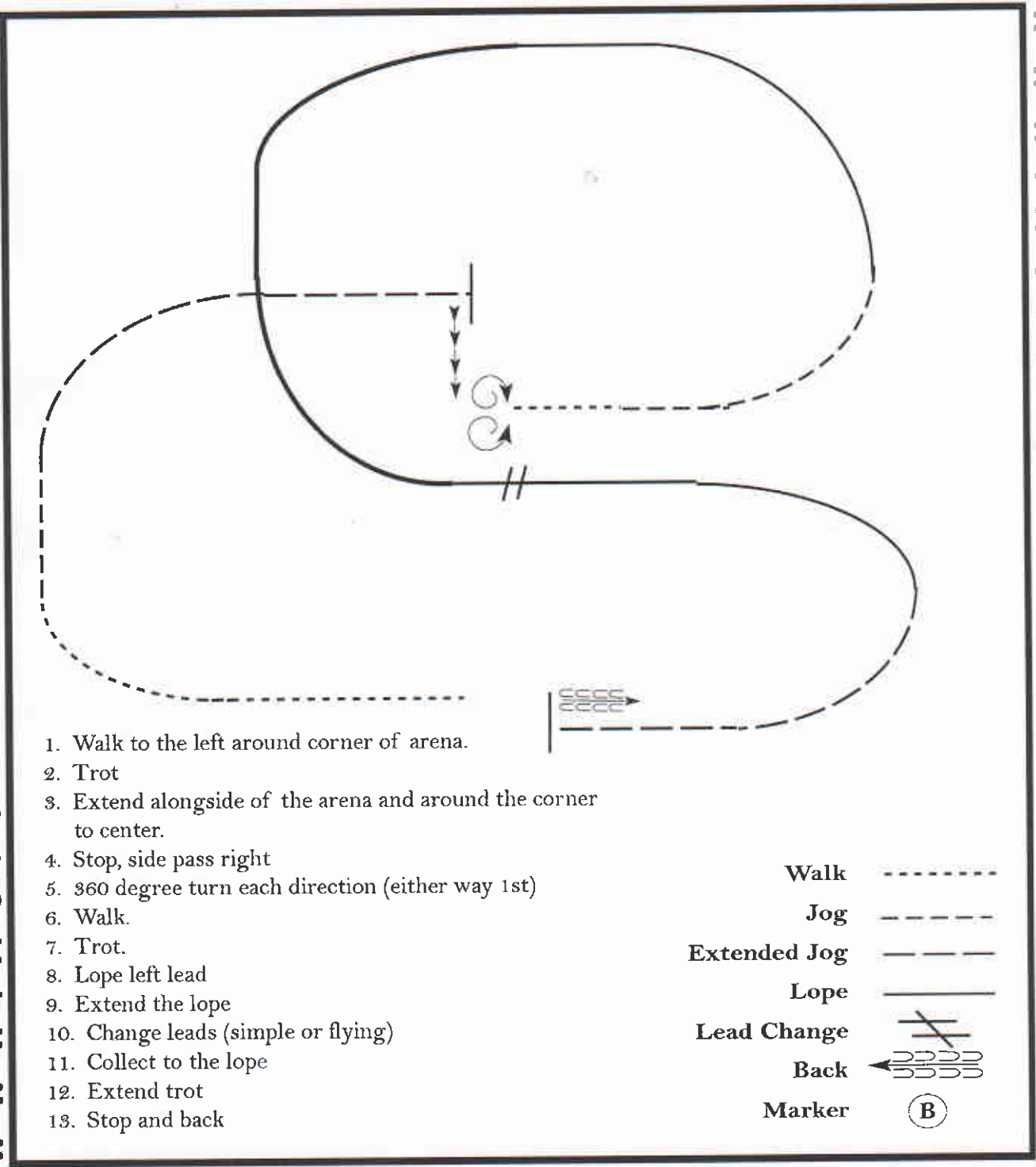

1. Walk to the left around corner of arena.
2. Trot
3. Extend alongside of the arena and around the corner to center.
4. Stop, side pass right
5. 360 degree turn each direction (either way 1st)
6. Walk.
7. Trot.
8. Lope left lead
9. Extend the lope
10. Change leads (simple or flying)
11. Collect to the lope
12. Extend trot
13. Stop and back

Walk	
Jog	
Extended Jog	
Lope	
Lead Change	
Back	
Marker	

[RR/3]

Pattern Provided by:  
*Kimberly Garrett*

# Iowa Paint Horse Show

## Reining (All)

Show Date:

www.HorseShowPatterns.com

www.HorseShowPatterns.com

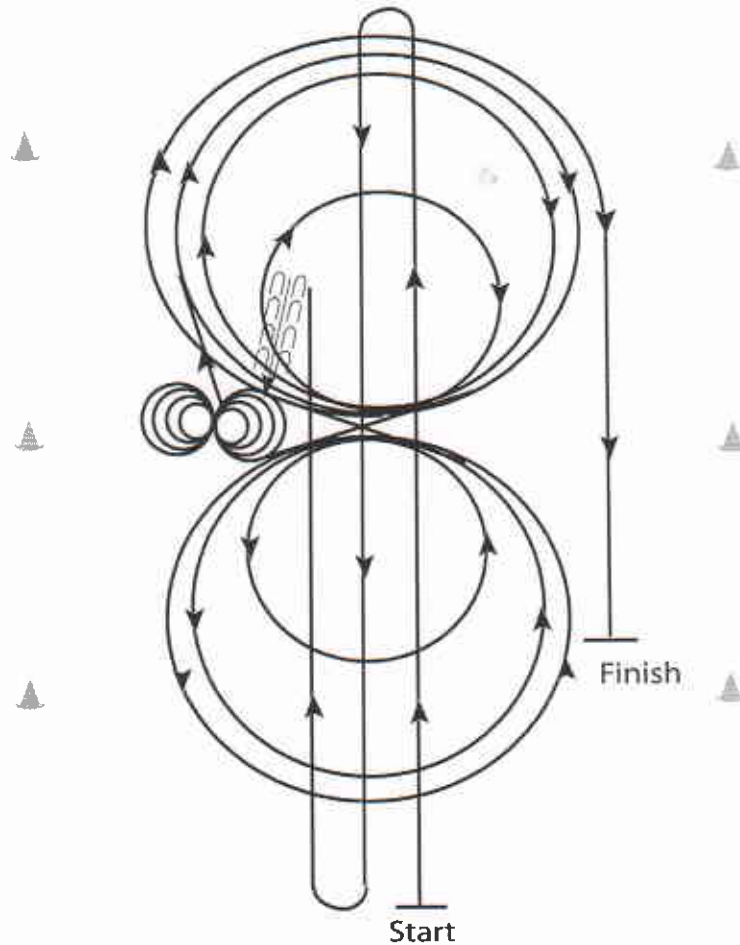

1. Run at speed to the far end of the arena past the end marker and do a left rollback – no hesitation.
2. Run to the opposite end of the arena past the end marker and do a right rollback – no hesitation.
3. Run past the center marker and do a sliding stop. Back up to the center of the arena at least ten feet (3m). Hesitate.
4. Complete four spins to the right.
5. Complete four and one-quarter spins to the left so that horse is facing left wall or fence. Hesitate.
6. Beginning on the right lead, complete three circles to the right: the first two circles large and fast; the third circle small and slow. Change leads at the center of the arena.
7. Complete three circles to the left: the first two circles large and fast; the third circle small and slow. Change leads at the center of the arena.
8. Begin a large fast circle to the right but do not close this circle. Run straight down the right side of the arena past the center marker and do a sliding stop at least twenty feet (6.09m) from the wall or fence. Hesitate to demonstrate completion of the pattern.  
Rider may drop bridle to the designated judge.

[R/AQHAP-7]

Pattern Provided by:  
*Kimberly Garrett*

SUNDAY'S  
PATTERNS



# IPHC Show

## Showmanship (Walk-Trot)

Show Date: 07/22/2018



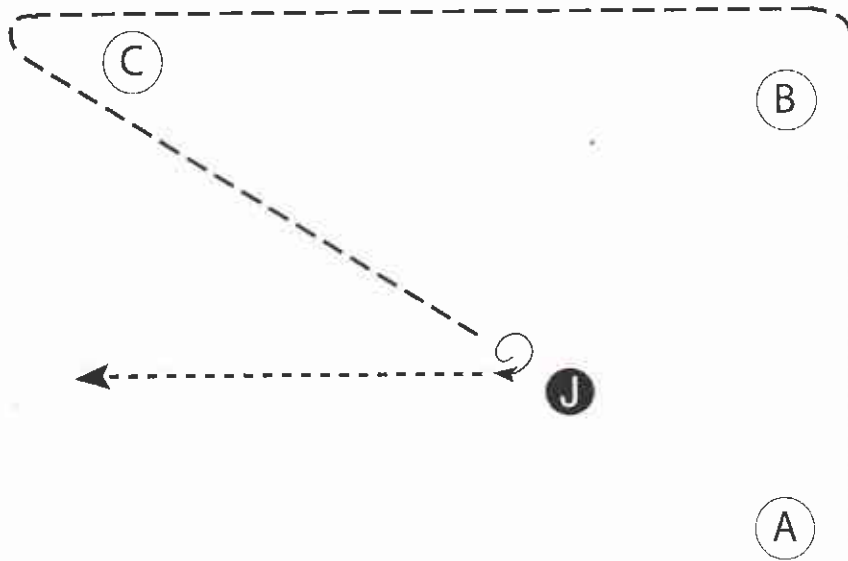

w w w . H o r s e S h o w P a t t e r n s . c o m

w w w . H o r s e S h o w P a t t e r n s . c o m

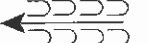

Be ready at A.

1. Walk to B.
2. At B, trot to and around C and to the judge.
3. Stop and set up for inspection.
4. When dismissed, turn 405 degrees and exit at a walk.

- Walk 
- Trot 
- Back 
- Marker 
- Judge 

[SWT-25]

Pattern Provided by:

*Cindy Mergaert*

# IPHC Show

## Showmanship (Nov. Youth & Nov. Amateur)

Show Date: 07/22/2018

w w w . H o r s e S h o w P a t t e r n s . c o m

w w w . H o r s e S h o w P a t t e r n s . c o m

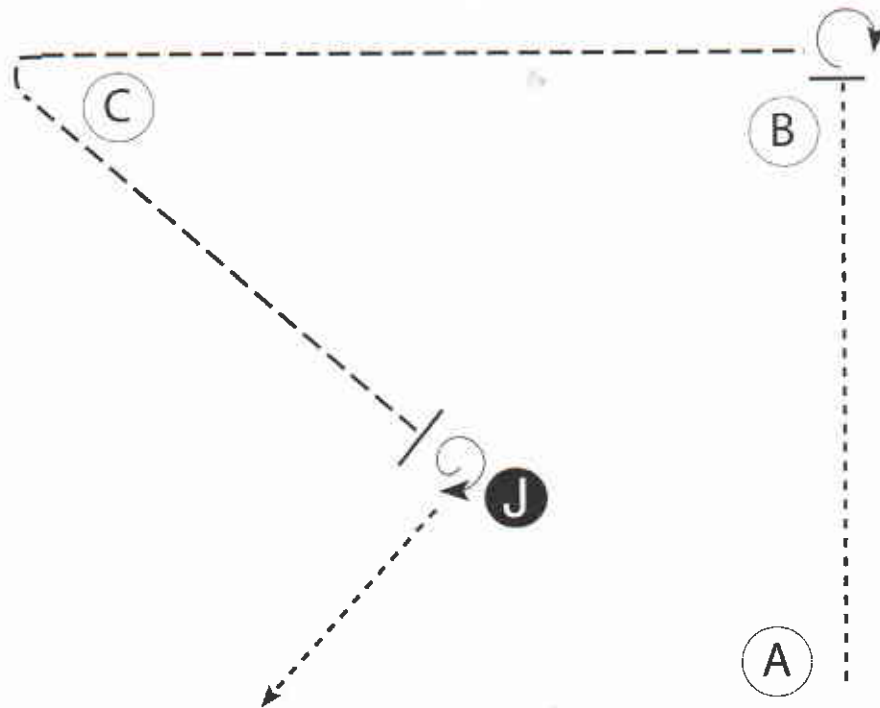

Be ready at A.

1. Walk to and past B.
2. Turn 270 degrees.
3. Trot to and around C to judge.
4. Stop at judge and set up for inspection.
5. Turn approximately 45 degrees as shown.
6. Exit at a walk.

Follow the instructions of your ring steward.

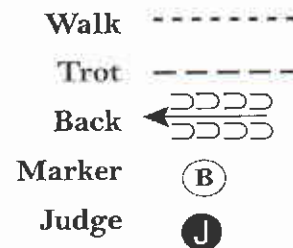

[S/1-25]

Pattern Provided by:  
*Cindy Mergaert*

# IPHC Show

## Showmanship (Youth & Amateur)

Show Date: 07/22/2018

w w w . H o r s e S h o w P a t t e r n s . c o m

w w w . H o r s e S h o w P a t t e r n s . c o m

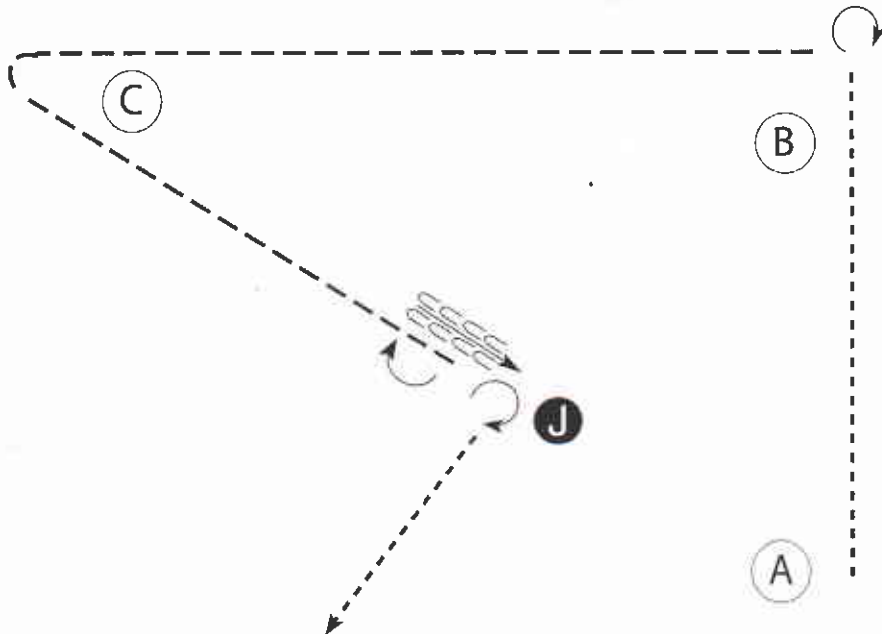

Be ready at A.

1. Walk to and past B.
2. Turn 270 degrees.
3. Trot to and around C.
4. When 2 horse lengths from the judge, stop.
5. Turn 180 degrees.
6. Back to judge and set up for inspection.
7. When dismissed, turn 270 degrees and exit at a walk.

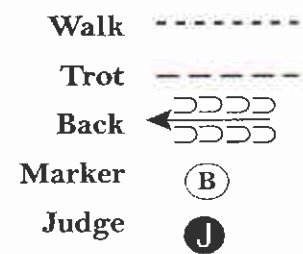

[S/2-25]

Pattern Provided by:  
*Cindy Mergaert*

# IPHC Show

## Hunt Seat Equitation (Walk-Trot)

Show Date: 07/22/2018

w w w . H o r s e S h o w P a t t e r n s . c o m

w w w . H o r s e S h o w P a t t e r n s . c o m

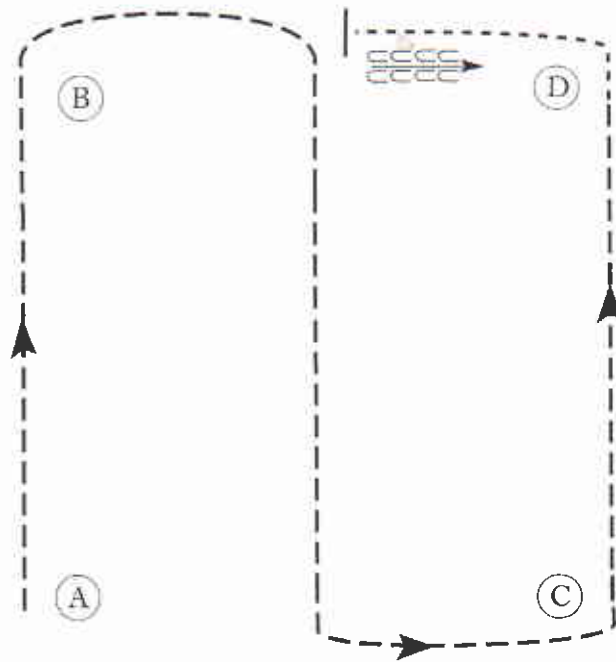

Be ready at A.

1. Posting trot to and around B on the left diagonal.
2. Halfway between B and C, change diagonals.
3. Posting trot on the right diagonal to and around C.
4. Continue to trot to D.
5. At D, walk.
6. Walk until halfway to B, stop and back one horse length.

Walk	-----
Trot	- - - - -
Extended Trot	-----
Canter	-----
Leg Yield	
Lead Change	
Back	←←←
Marker	(B)
Sidepass	←←
Hand Gallop	-----

[HSE/WT-25]

Pattern Provided by:

*Cindy Mergaert*

# IPHC Show

## Hunt Seat Equitation (Nov. Youth & Nov. Amateur)

Show Date: 07/22/2018

www.HorseShowPatterns.com

www.HorseShowPatterns.com

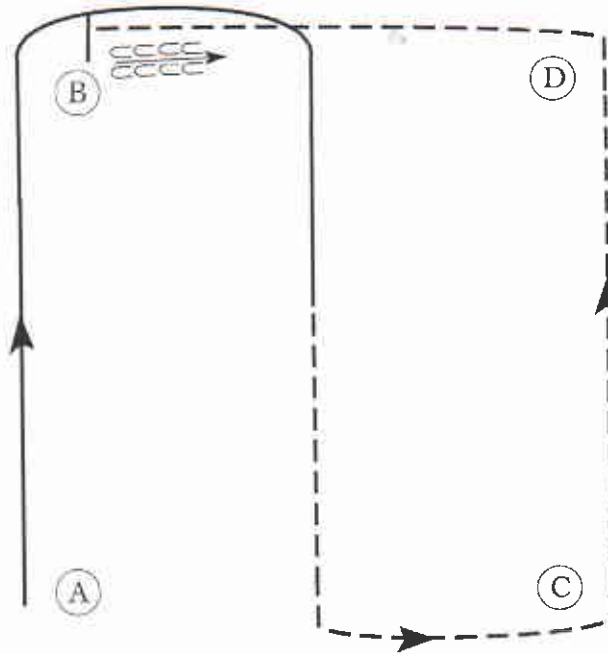

Be ready at A.

1. Canter on the right lead to and around B.
2. Halfway between B and C, break to the trot.
3. Posting trot on the right diagonal to C.
5. At C, change diagonals and continue to trot to D.
6. At D, sitting trot to B.
7. At B, stop and back one horse length.

Walk	-----
Trot	- - - - -
Extended Trot	-----
Canter	-----
Leg Yield	
Lead Change	
Back	←←←←←
Marker	Ⓚ
Sidepass	←→
Hand Gallop	-----

[HSE/1-25]

Pattern Provided by:

*Cindy Mergaert*

# IPHC Show

## Hunt Seat Equitation (Youth & Amateur)

Show Date: 07/22/2018

www.HorseShowPatterns.com

www.HorseShowPatterns.com

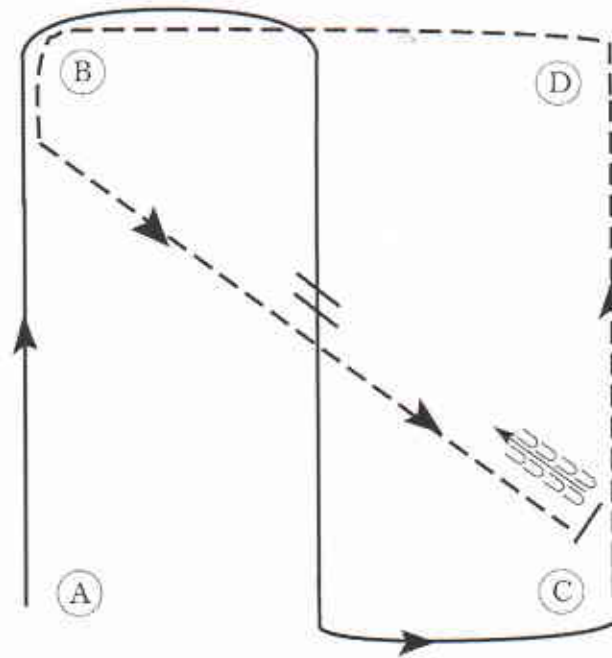

Be ready at A.

1. Canter on the right lead to and around B.
2. Halfway between B and C, change leads.
3. Canter on left lead to and around C.
4. Posting trot on the left diagonal from C to D.
5. At D, change diagonals and continue to trot to B.
6. At B, sitting trot to C.
7. Stop and back one horse length at C.

Walk	-----
Trot	- - - - -
Extended Trot	—————
Canter	—————
Leg Yield	
Lead Change	///
Back	←←←
Marker	(B)
Sidepass	←←←
Hand Gallop	—————

[HSE/2-25]

Pattern Provided by:

*Cindy Mergaert*

# IPHC Show

## Youth & Am Walk-Trot Horsemanship

Show Date: 07/22/2018

www.HorseShowPatterns.com

www.HorseShowPatterns.com

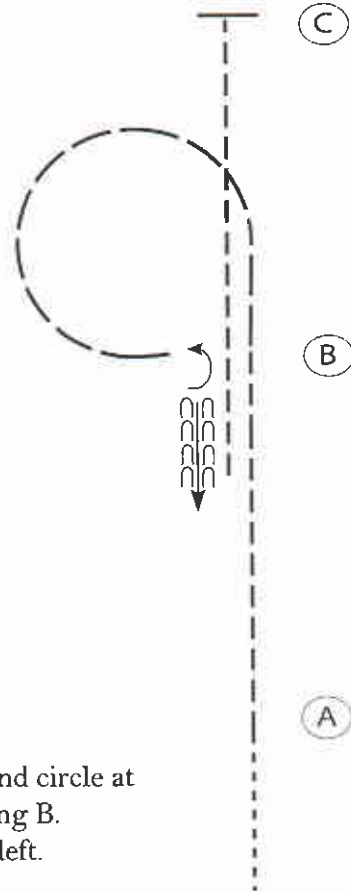

Begin before A at a walk.

1. Jog from A to B.
2. At B, extend the jog and circle at B as shown. Stop facing B.
3. Turn 1/4 turn to the left.
4. Back one horse length.
5. Jog to C. Stop at C.

Follow the instructions of your ring steward.

Walk	-----
Jog	-----
Extended Jog	-----
Lope	-----
Leg Yield	
Lead Change	-----
Back	← C C C C C C C C C C
Marker	(B)
Sidepass	←-----→

[WH/WT-17]

Pattern Provided by:

*Cindy Mergaert*

# IPHC Show

Nov. Yth & Nov. Am Horsemanship

Show Date: 07/22/2018

www.HorseShowPatterns.com

www.HorseShowPatterns.com

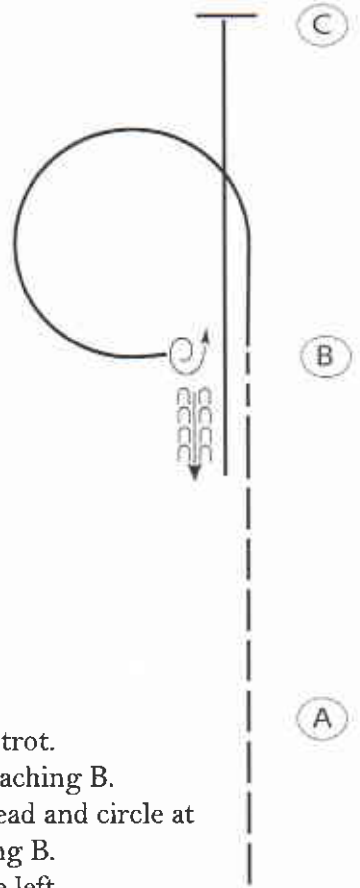

Begin before A.

1. Pass A at an extended trot.
2. Slow to a jog before reaching B.
3. At B, lope on the left lead and circle at B as shown. Stop facing B.
4. Turn 1 1/4 turn to the left.
5. Back one horse length.
6. Lope on the right lead to C. Stop at C.

Follow the instructions of your ring steward.

Walk	-----
Jog	- - - - -
Extended Jog	— — — — —
Lope	—————
Leg Yield	
Lead Change	↗ ↘
Back	←←←←←
Marker	(B)
Sidepass	←→

[WH/3-17]

Pattern Provided by:

*Cindy Mergaert*



# IPHC Show

## Youth & Amateur Horsemanship

Show Date: 07/22/2018

www.HorseShowPatterns.com

www.HorseShowPatterns.com

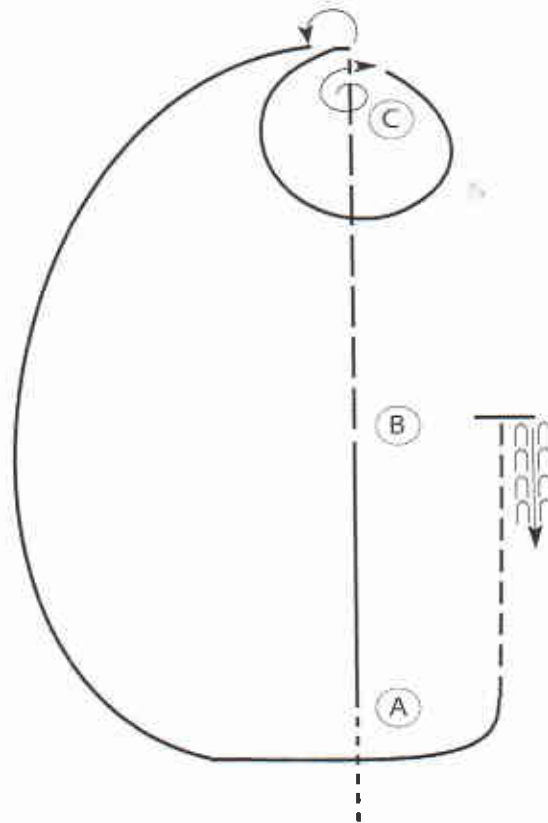

Be ready before A.

1. Walk to A.
2. At A, lope on the left lead to B.
3. At B, extend the jog to past C.
4. Stop and perform a 450 degree turn to the right.
5. Lope a circle around C on the right lead.
6. Stop at C and perform a 180 degree turn to the left.
7. Lope a large fast half circle to and around A .
8. At A, jog to B.
9. Stop at B and back 4 approximately one horse length.

Walk	-----
Jog	- - - - -
Extended Jog	- - - - -
Lope	—————
Lead Change	⚡
Back	← — — — —
Marker	ⓑ

[WH/3-8]

Pattern Provided by:

*Cindy Mergaert*

# IPHC Show

## Green Western Riding

Show Date: 07/22/2018

w w w . H o r s e S h o w P a t t e r n s . c o m

w w w . H o r s e S h o w P a t t e r n s . c o m

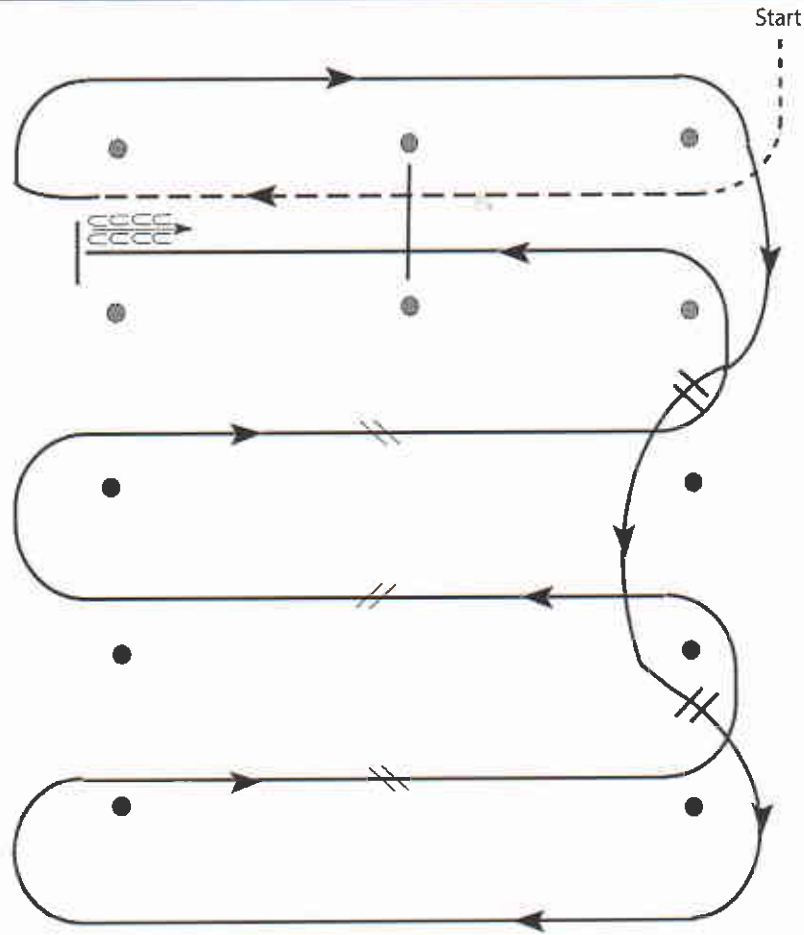

1. Walk, transition to jog, jog over log.
2. Transition to right lead and lope around end.
3. First line change.
4. Second line change. Lope around end of arena.
5. First crossing change.
6. Second crossing change.
7. Third crossing change.
8. Lope over log.
9. Lope, stop and back.

[WR/GP-4]

Pattern Provided by:

*Cindy Mergaert*

## Western Riding Pattern #5

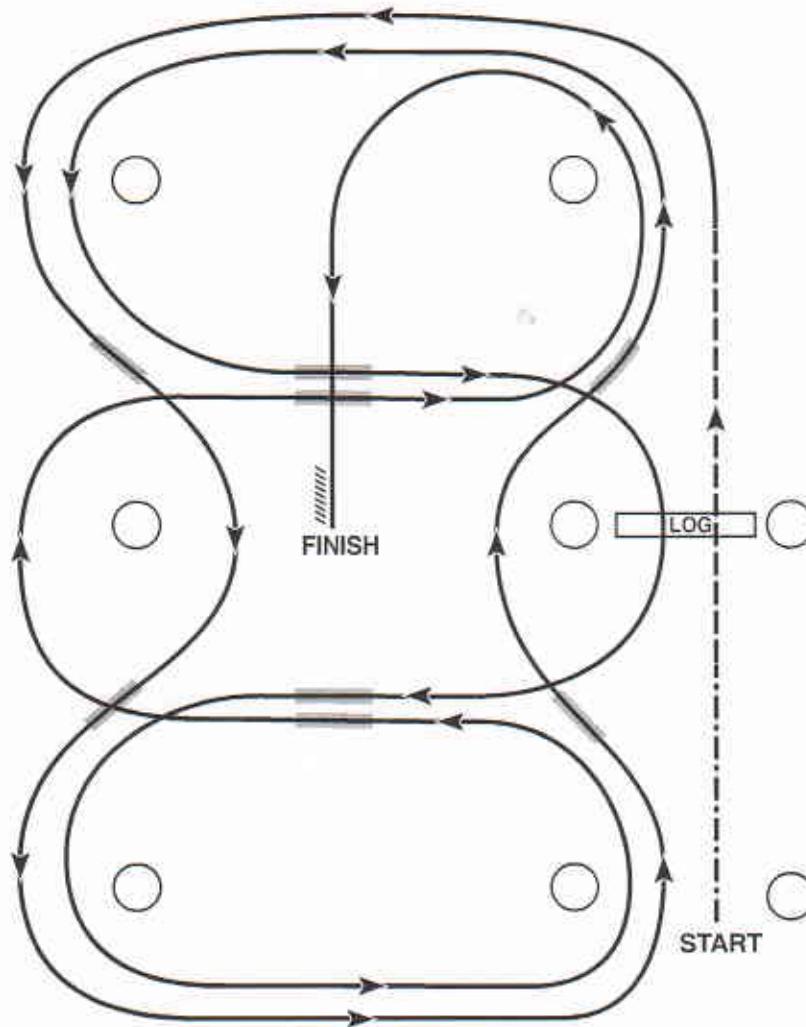

Recommended for small arenas.

1. Walk, transition to jog, jog over log.
2. Transition to the lope, on the left lead.
3. First line change.
4. Second line change.
5. Third line change.
6. Fourth line change.
7. First crossing change.
8. Lope over log.
9. Second crossing change.
10. Third crossing change.
11. Fourth crossing change.
12. Lope, stop and back.

# IOWA PAINT HORSE CLUB

July 22nd

All Walk Trot &  
In hand

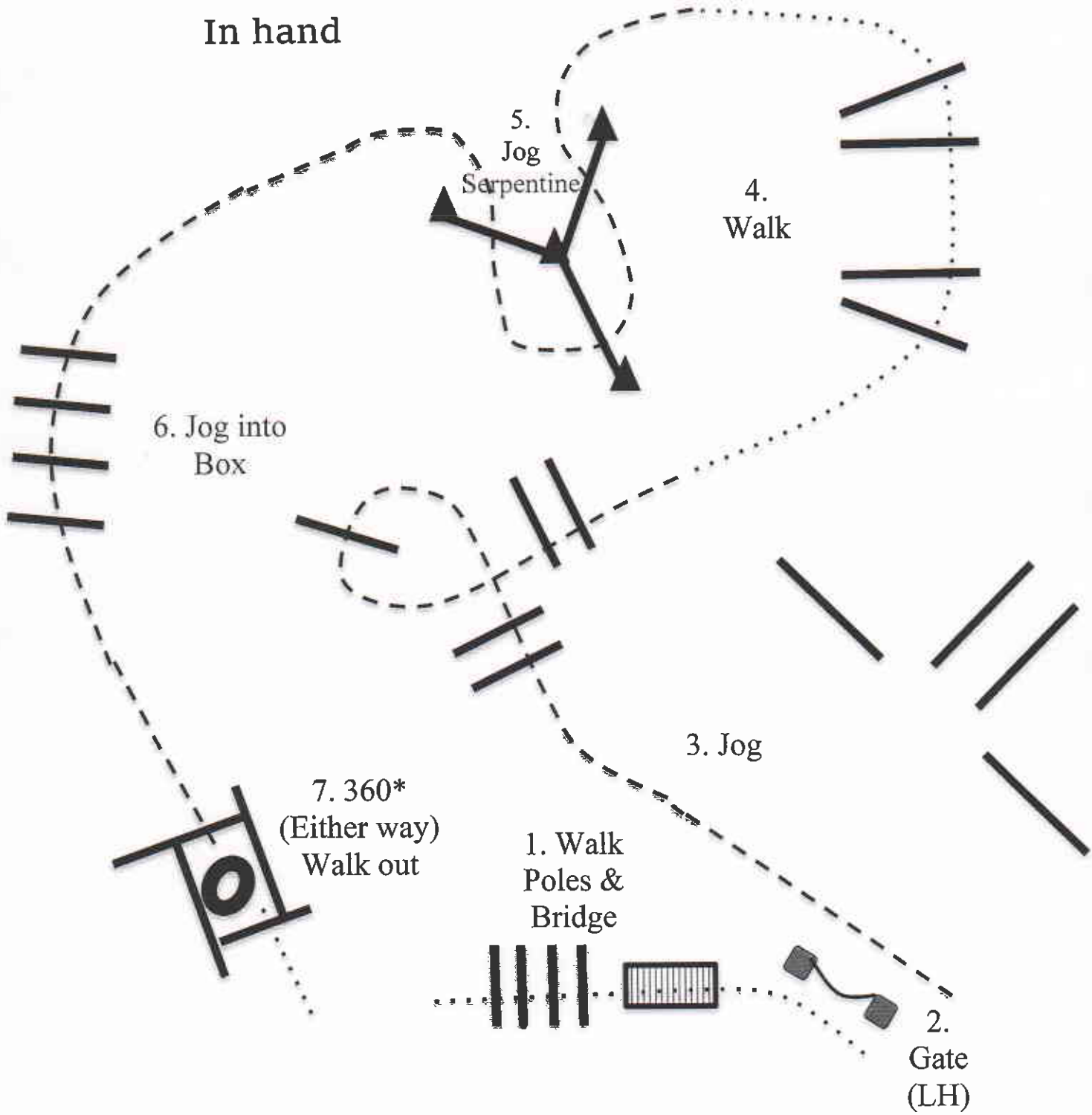

# IOWA PAINT HORSE CLUB

## July 22nd

### All Trail

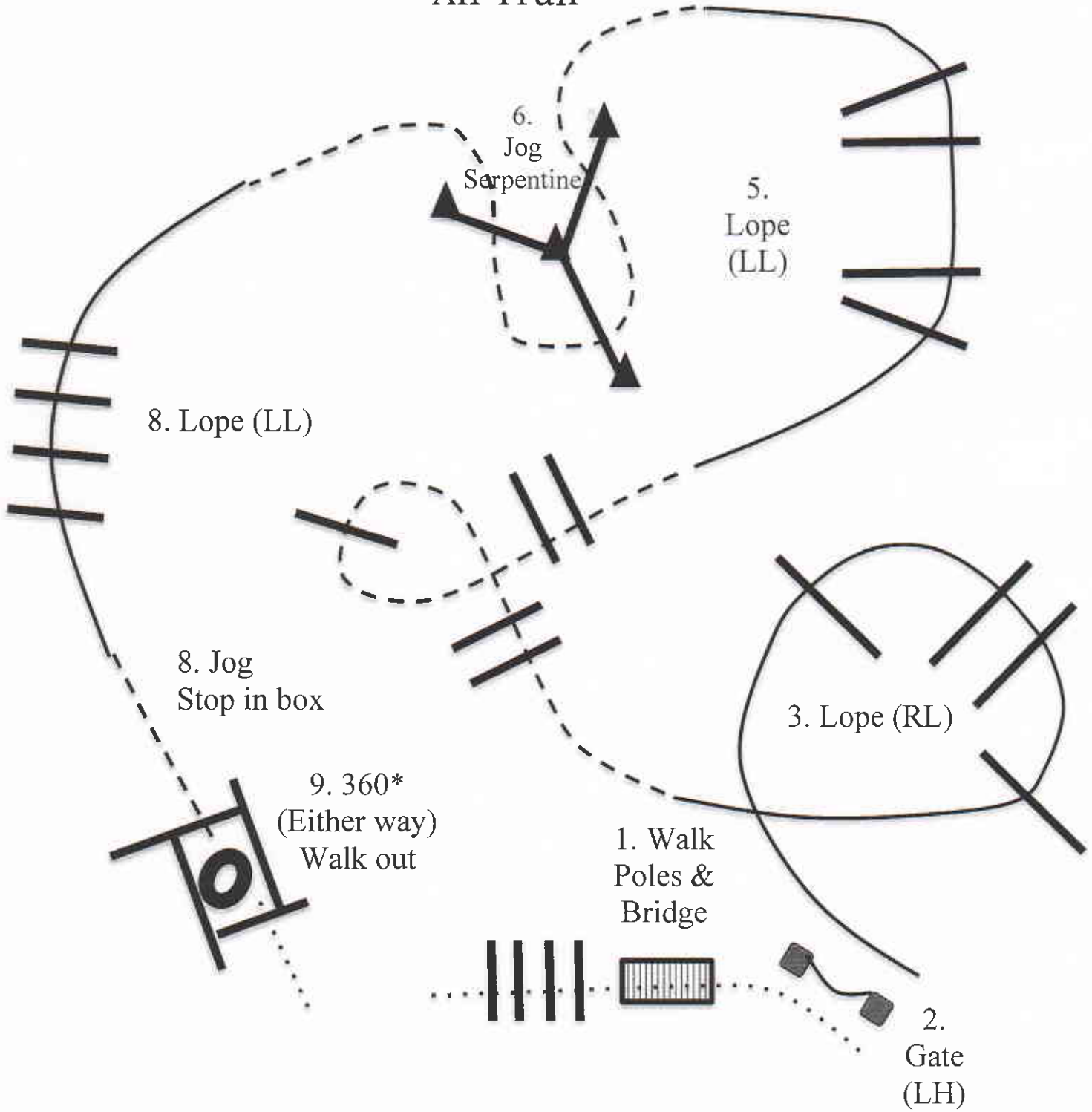

# IPHC Show

## All Ranch Riding Classes

Show Date: 07/22/2018

www.HorseShowPatterns.com

www.HorseShowPatterns.com

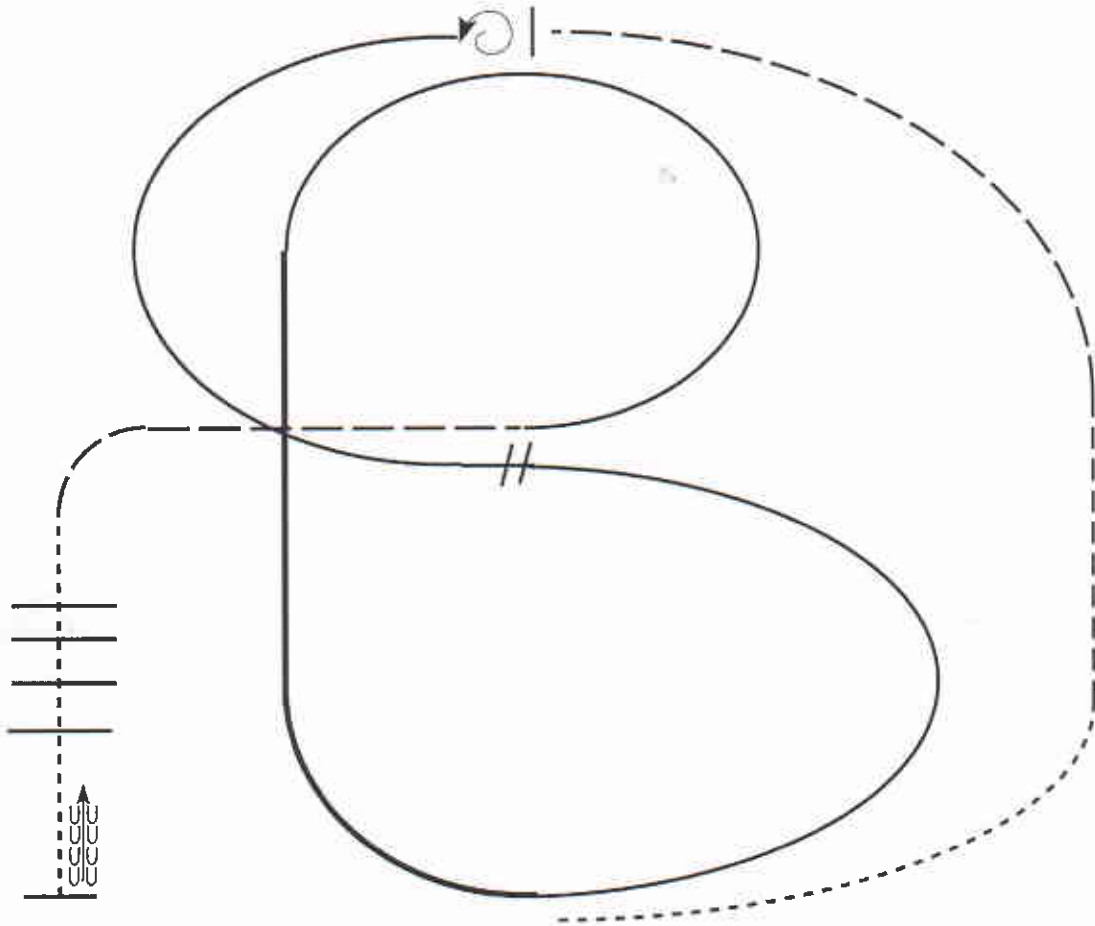

1. Walk
2. Trot
3. Extend the trot, at the top of the arena, stop
4. 360 degree turn to the left
5. Left lead 1/2 circle, lope to the center
6. Change leads (simple or flying)
7. Right lead 1/2 circle
8. Extended lope up the long side of arena (right lead)
9. Collect back to a lope around the top of the arena and back to center
10. Break down to an extended trot
11. Walk over poles.
12. Stop and back

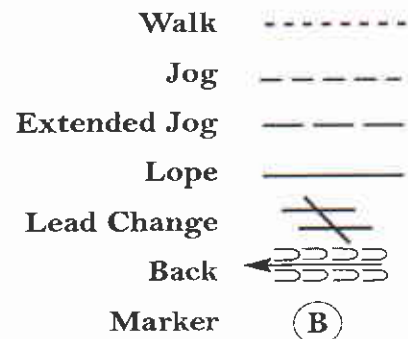

[RR/1]

Pattern Provided by:

*Cindy Mergaert*

# Iowa Paint Horse Show

## Reining (All)

Show Date:

W W W . H O R S E S H O W P A T T E R N S . C O M

W W W . H O R S E S H O W P A T T E R N S . C O M

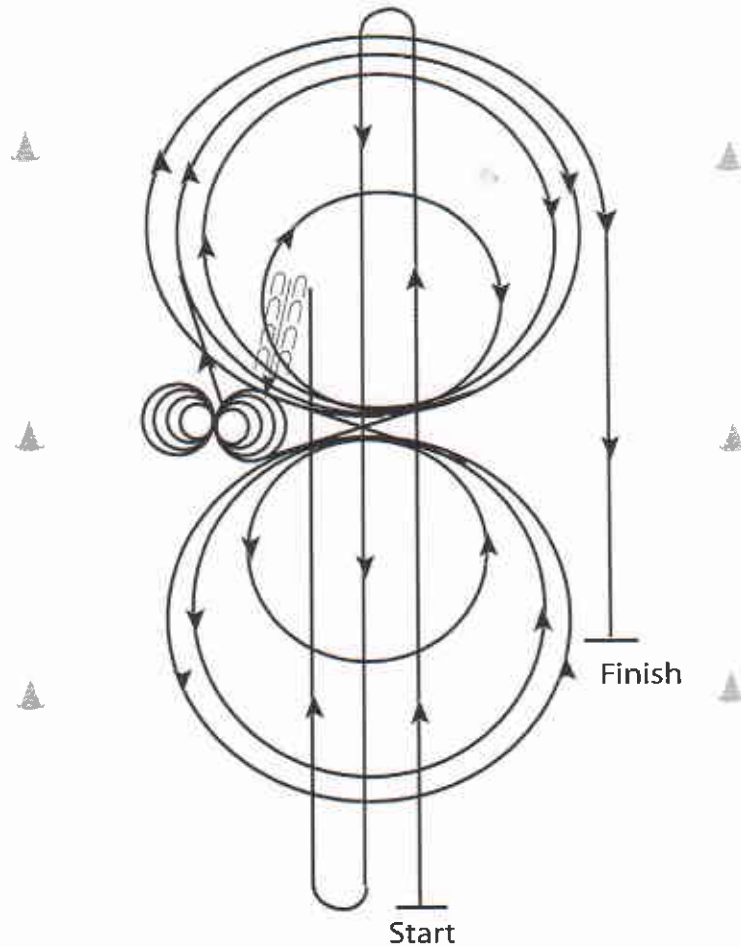

1. Run at speed to the far end of the arena past the end marker and do a left rollback – no hesitation.
2. Run to the opposite end of the arena past the end marker and do a right rollback – no hesitation.
3. Run past the center marker and do a sliding stop. Back up to the center of the arena at least ten feet (3m). Hesitate.
4. Complete four spins to the right.
5. Complete four and one-quarter spins to the left so that horse is facing left wall or fence. Hesitate.
6. Beginning on the right lead, complete three circles to the right: the first two circles large and fast; the third circle small and slow. Change leads at the center of the arena.
7. Complete three circles to the left: the first two circles large and fast; the third circle small and slow. Change leads at the center of the arena.
8. Begin a large fast circle to the right but do not close this circle. Run straight down the right side of the arena past the center marker and do a sliding stop at least twenty feet (6.09m) from the wall or fence. Hesitate to demonstrate completion of the pattern.  
Rider may drop bridle to the designated judge.

[R/AQHAP-7]

Pattern Provided by:  
*Kimberly Garrett*