



# IOWA PAINT HORSE CLUB



**Memorial Day Classic**  
**Cedar Rapids, IA**  
**5/27-29/2017**

**SATURDAY JUDGES:**

Leon Borcharding (OK)  
Cindy Mergaert (FL)  
Mike Sheppard (IL)  
Bill Mitchell (KY)

**SUNDAY/MONDAY JUDGES:**

Kathryn Boggetta (MI)  
Heather Young (TX)  
Pat Trebsch (TX)  
Michele Pearson (AZ)

**NEW FORMAT!**  
Saturday – Amateur/Youth Show  
Sunday/Monday – Full show,  
split/combined

Pattern Book: \$5.00



# Iowa Paint Horse Club Show

## Adult and Youth Walk-Trot Showmanship

W W W . H O R S E S H O W P A T T E R N S . C O M

W W W . H O R S E S H O W P A T T E R N S . C O M

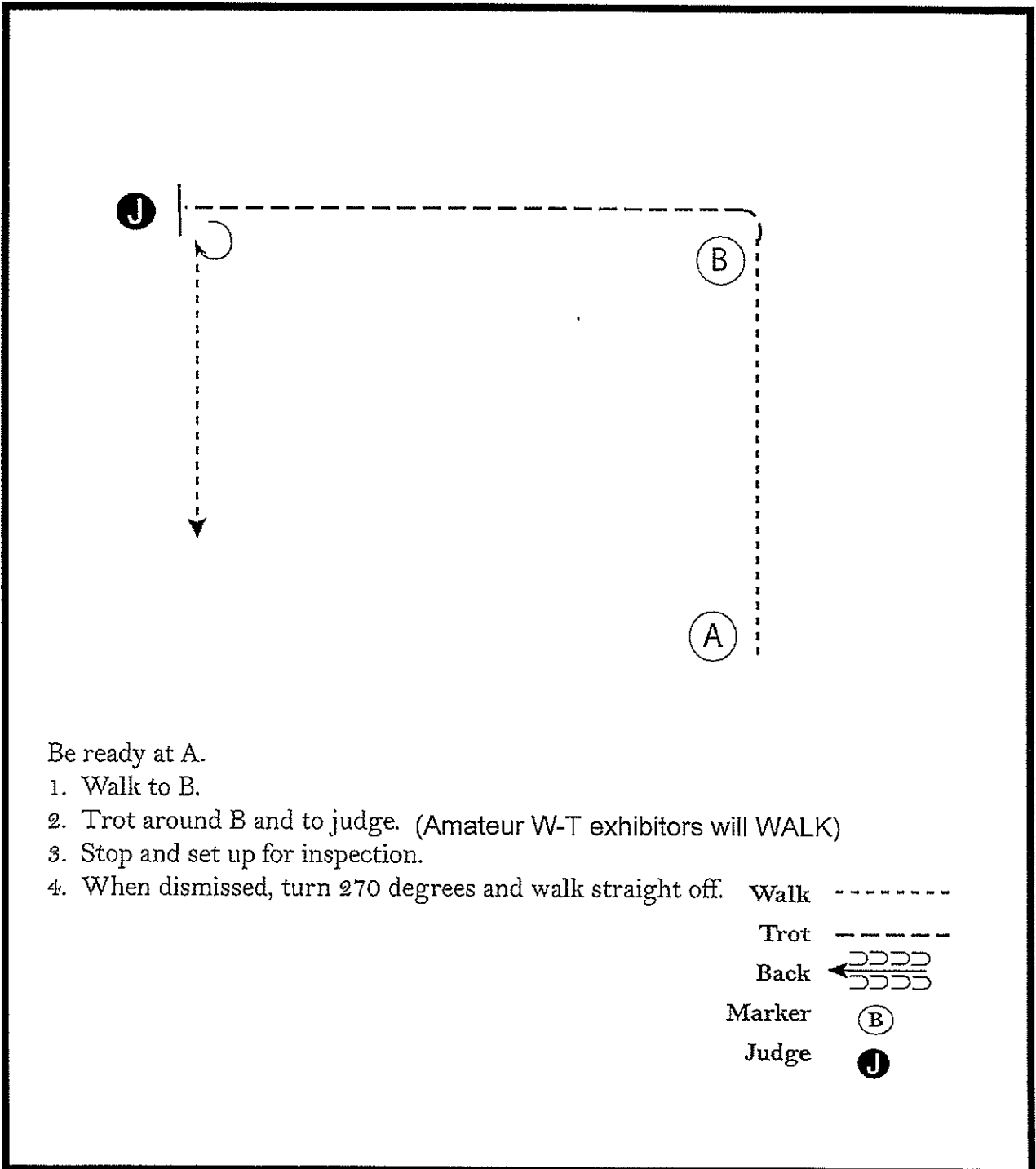

Be ready at A.

1. Walk to B.
2. Trot around B and to judge. (Amateur W-T exhibitors will WALK)
3. Stop and set up for inspection.
4. When dismissed, turn 270 degrees and walk straight off.

Walk -----  
 Trot - - - - -  
 Back ← - - - -  
 Marker (B)  
 Judge (J)

[S/WT-23]

Pattern Provided by:  
*Cindy Mergaert*

# Iowa Paint Horse Club Show

## Nov Youth, Nov Amateur Showmanship

W W W . H O R S E S H O W P A T T E R N S . C O M

W W W . H O R S E S H O W P A T T E R N S . C O M

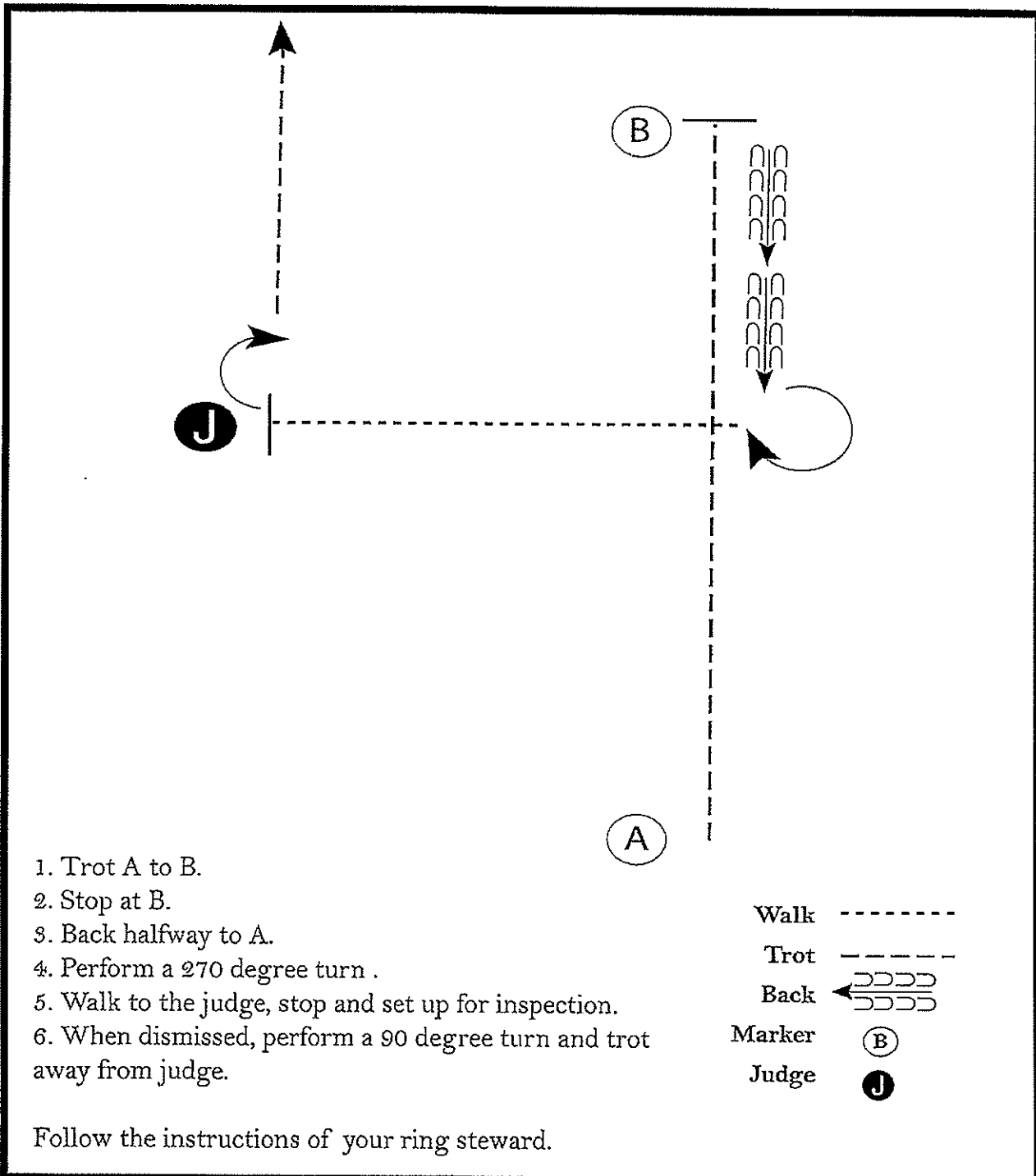

1. Trot A to B.
2. Stop at B.
3. Back halfway to A.
4. Perform a 270 degree turn .
5. Walk to the judge, stop and set up for inspection.
6. When dismissed, perform a 90 degree turn and trot away from judge.

- Walk -----
- Trot - - - - -
- Back ← ~~~~~
- Marker (B)
- Judge (J)

Follow the instructions of your ring steward.

[S/WT-1]

Pattern Provided by:  
*Cindy Mergaert*

# Iowa Paint Horse Club Show

SPB Amateur, Youth and Amateur Showmanship

W W W . H O R S E S H O W P A T T E R N S . C O M

W W W . H O R S E S H O W P A T T E R N S . C O M

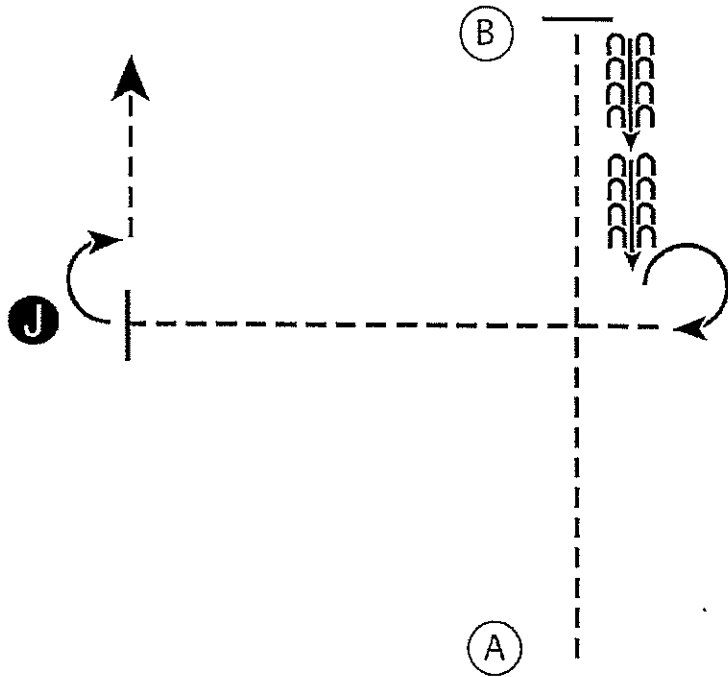

1. Trot A to B
2. Stop at B and back halfway to A
3. Stop and perform a 270 degree turn
4. Trot to judge and set up for inspection
5. When dismissed perform a 90 degree turn and trot away from judge

Walk .....  
Trot - - - - -  
Back ← CCCC  
Marker (B)  
Judge (J)

[S/2-3]

Pattern Provided by:  
*Cindy Mergaert*

# Iowa Paint Horse Club Show

## Adult and Youth Walk-Trot Hunt Seat Equitation

www.HorseShowPatterns.com

www.HorseShowPatterns.com

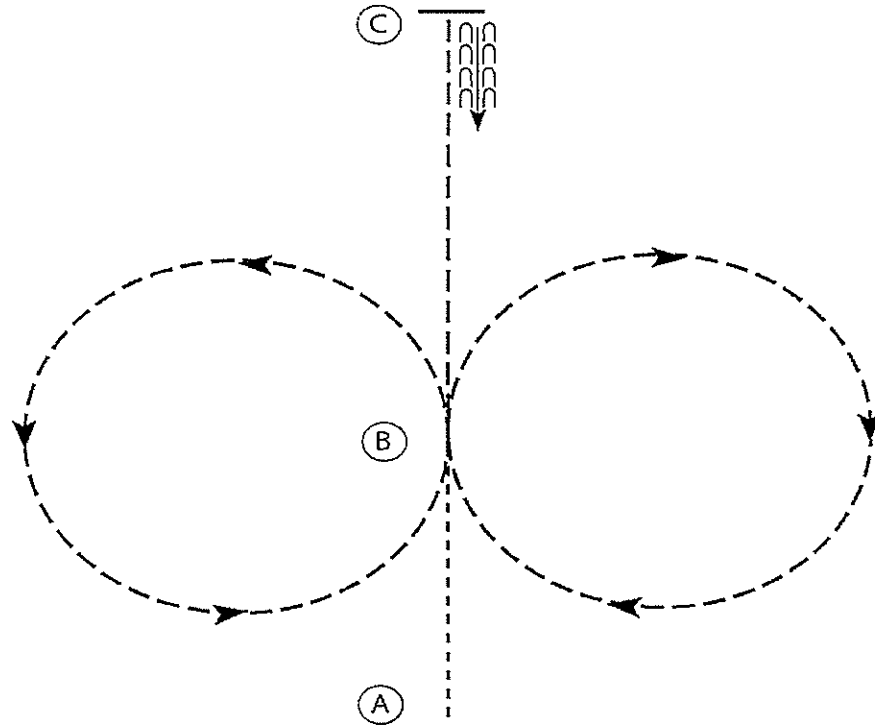

1. Walk A to B.
2. At B posting trot a circle to the right on the proper diagonal.
3. At B posting trot a circle to the left on the proper diagonal.
4. At B sitting trot to C.
5. At C stop and back approximately one horse length.

Walk	-----
Trot	- - - - -
Extended Trot	-----
Canter	-----
Leg Yield	
Lead Change	—/—
Back	←←←←←
Marker	Ⓚ
Sidepass	←←←
Hand Gallop	-----

[HSE/WT-5]

Pattern Provided by:

*Cindy Mergaert*

# Iowa Paint Horse Club Show

## Nov. Youth, Nov. Amateur Hunt Seat Equitation

W W W . H O R S E S H O W P A T T E R N S . C O M

W W W . H O R S E S H O W P A T T E R N S . C O M

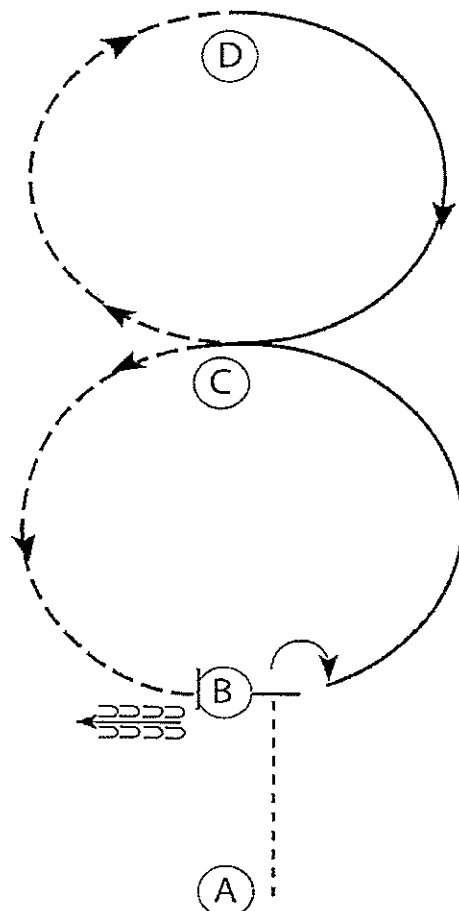

Be ready at A.

1. Walk to B.
2. Stop at B and perform a 90 degree turn to the right on the forehand.
3. Canter on the left lead to C.
4. Posting trot from C to D.
5. Canter on the right lead from D to C.
6. Posting trot from C to B.
7. Stop at B and back one horse length.

Follow the instructions of your ring steward.

Walk	-----
Trot	- - - - -
Extended Trot	— — — — —
Canter	—————
Leg Yield	
Lead Change	— / —
Back	←←←←←
Marker	Ⓚ
Sidepass	← - - - - ←
Hand Gallop	— — — — —

[HSE/2-13]

**Pattern Provided by:**  
*Cindy Mergaert*

# Iowa Paint Horse Club Show

## Youth and Amateur Hunt Seat Equitation

www.HorseShowPatterns.com

www.HorseShowPatterns.com

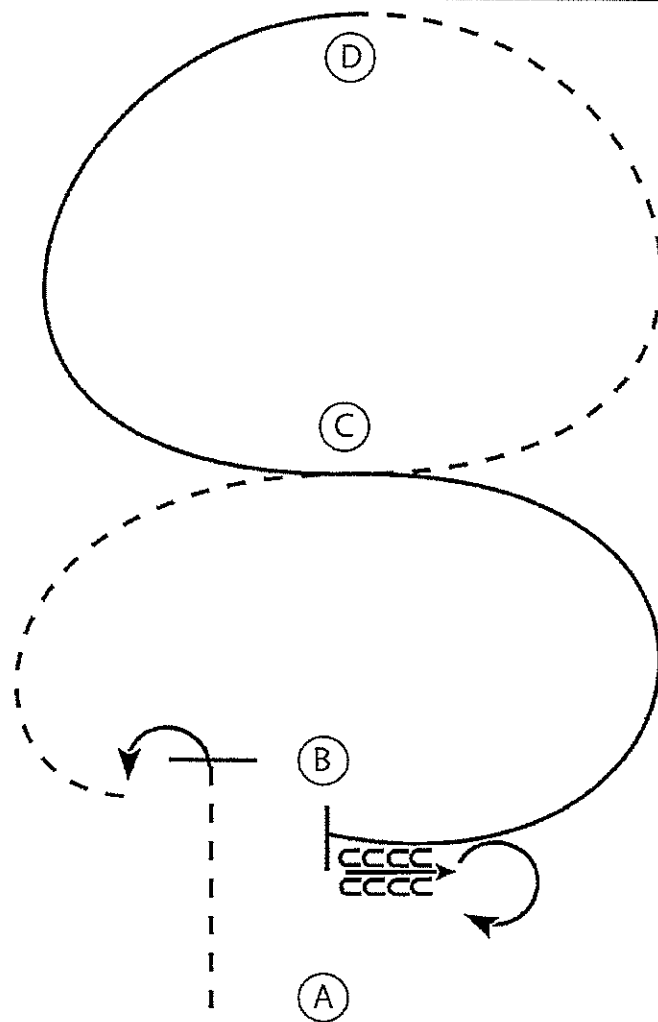

1. Sitting trot A to B
2. Stop at B and perform a 90 degree turn to the left on the forehand
3. Posting trot on the left diagonal in a half circle to C
4. At C change diagonals and posting trot a half circle to D
5. At D canter on the left lead in a half circle to C and continue in a half circle to B
6. Stop at B and back 4 steps
7. Perform a 270 degree turn to the right on the hindquarters

Walk	.....
Trot	-----
Extended Trot	-----
Canter	—————
Leg Yield	
Lead Change	↘
Back	←←←←
Marker	⊙
Sidepass	←←←←

[HSE/3-7]

Pattern Provided by:  
*Cindy Mergaert*



# Hunter Hack (All Hunter Hack)

www.horsheshowpatterns.com

www.horsheshowpatterns.com

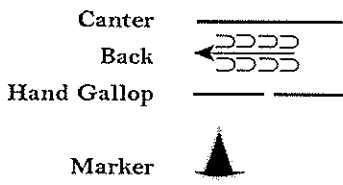
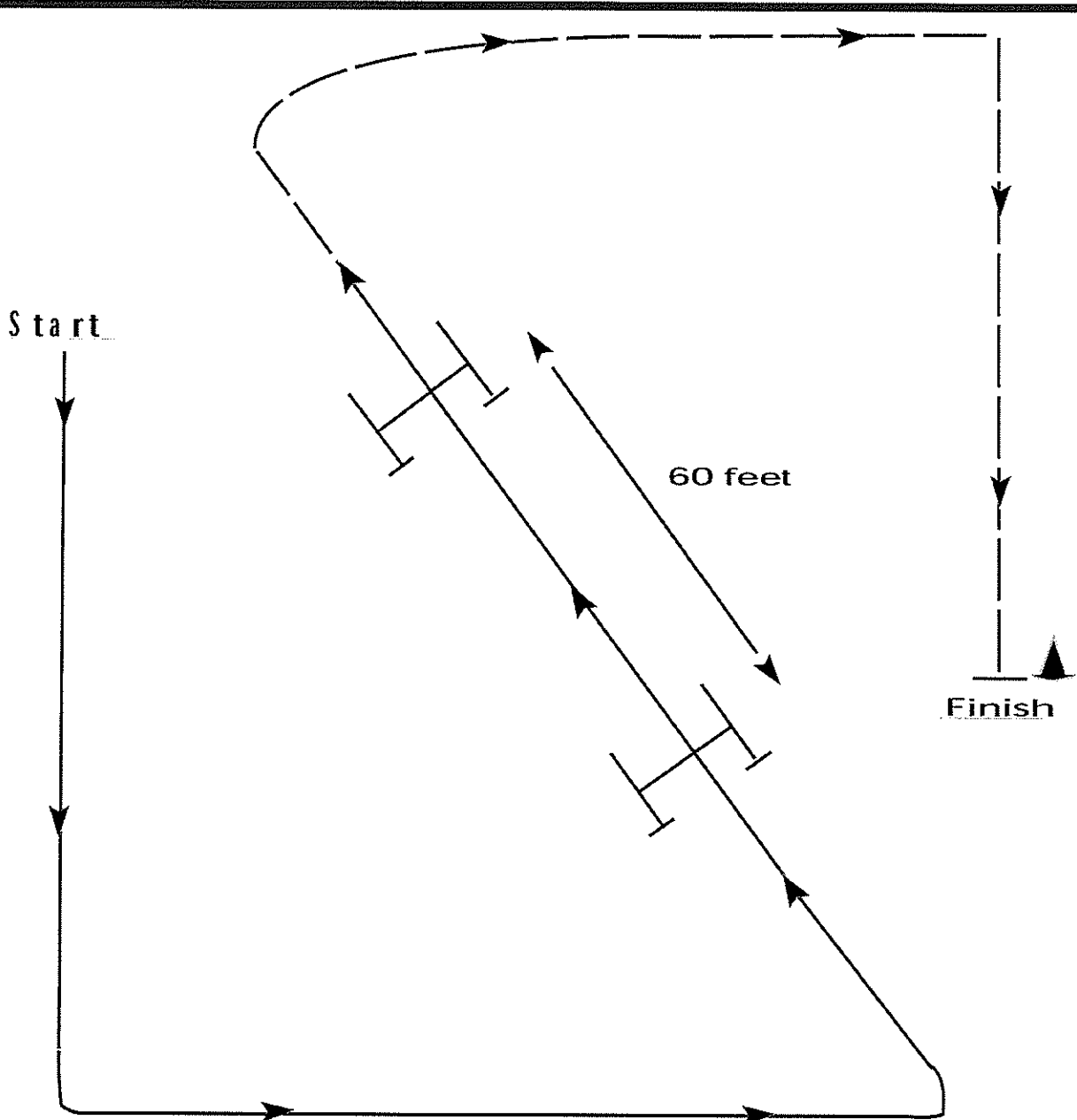

1. Fences are set approximately 60 feet apart.
2. After 2nd fence, hand gallop to marker and stop.
3. Drop your reins to signify completion.

[HH/60-11]

Pattern Provided by:

*The Judges*

# Iowa Paint Horse Club Show

## Adult and Youth Walk-Trot Horsemanship

www.HorseShowPatterns.com

www.HorseShowPatterns.com

- Begin before A at a walk.
1. Jog from A to B.
  2. At B, extend the jog and circle at B as shown. Stop facing B.
  3. Turn 1/4 turn to the left.
  4. Back one horse length.
  5. Jog to C. Stop at C.

Follow the instructions of your ring steward.

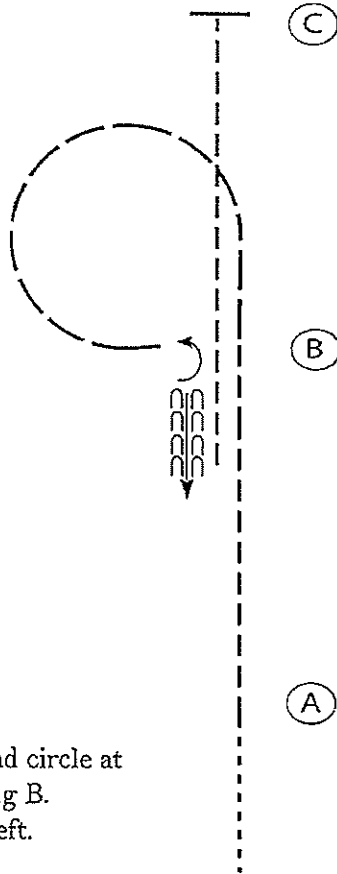

Walk	.....
Jog	-----
Extended Jog	-----
Lope	—————
Leg Yield	
Lead Change	—/—
Back	←←←←←
Marker	⊙ B
Sidepass	←-----→

[WH/WT-17]

Pattern Provided by:  
*Cindy Mergaert*

# Iowa Paint Horse Club Show

Nov. Youth, Nov. Amateur Horsemanship

www.HorseShowPatterns.com

www.HorseShowPatterns.com

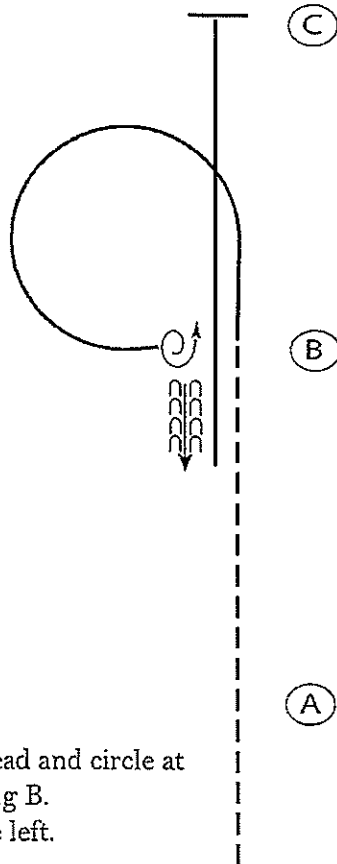

Begin before A at a jog.

1. Jog from A to B.
2. At B, lope on the left lead and circle at B as shown. Stop facing B.
3. Turn 1 1/4 turn to the left.
4. Back one horse length.
5. Lope on the right lead to C. Stop at C.

Follow the instructions of your ring steward.

Walk	-----
Jog	- - - - -
Extended Jog	-----
Lope	=====
Leg Yield	
Lead Change	↘
Back	←←←←←
Marker	⊙ B
Sidepass	←-----→

[WH/2-17]

Pattern Provided by:

*Cindy Mergaert*

# Iowa Paint Horse Club Show

## Youth and Amateur Horsemanship

W W W . H O R S E S H O W P A T T E R N S . C O M

W W W . H O R S E S H O W P A T T E R N S . C O M

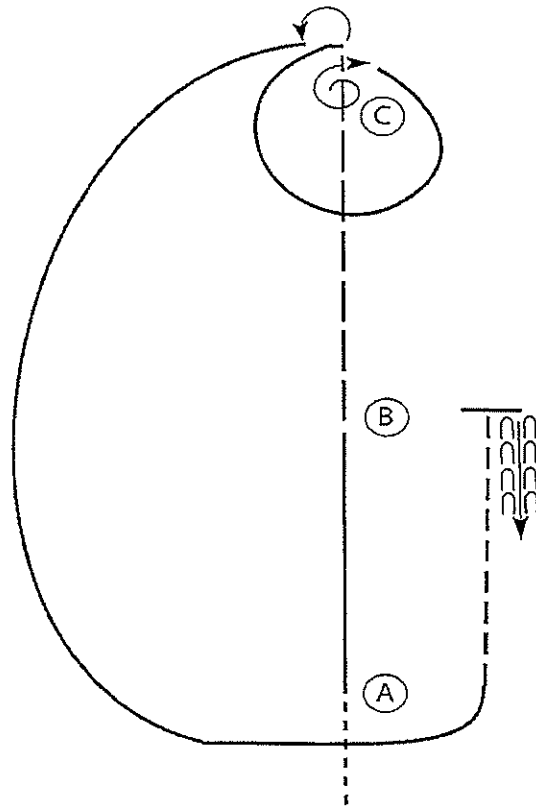

Be ready before A.

1. Walk to A.
2. At A, lope on the left lead to B.
3. At B, extend the jog to past C.
4. Stop and perform a 450 degree turn to the right.
5. Lope a circle around C on the right lead.
6. Stop at C and perform a 180 degree turn to the left.
7. Lope a large fast half circle to and around A .
8. At A, jog to B.
9. Stop at B and back 4 approximately one horse length.

Walk	-----
Jog	- - - - -
Extended Jog	—————
Lope	—————
Lead Change	///
Back	←←←←←
Marker	ⓑ

[WH/3-8]

Pattern Provided by:  
*Cindy Mergaert*

WESTERN RIDING PATTERN IV

WESTERN RIDING PATTERN IV

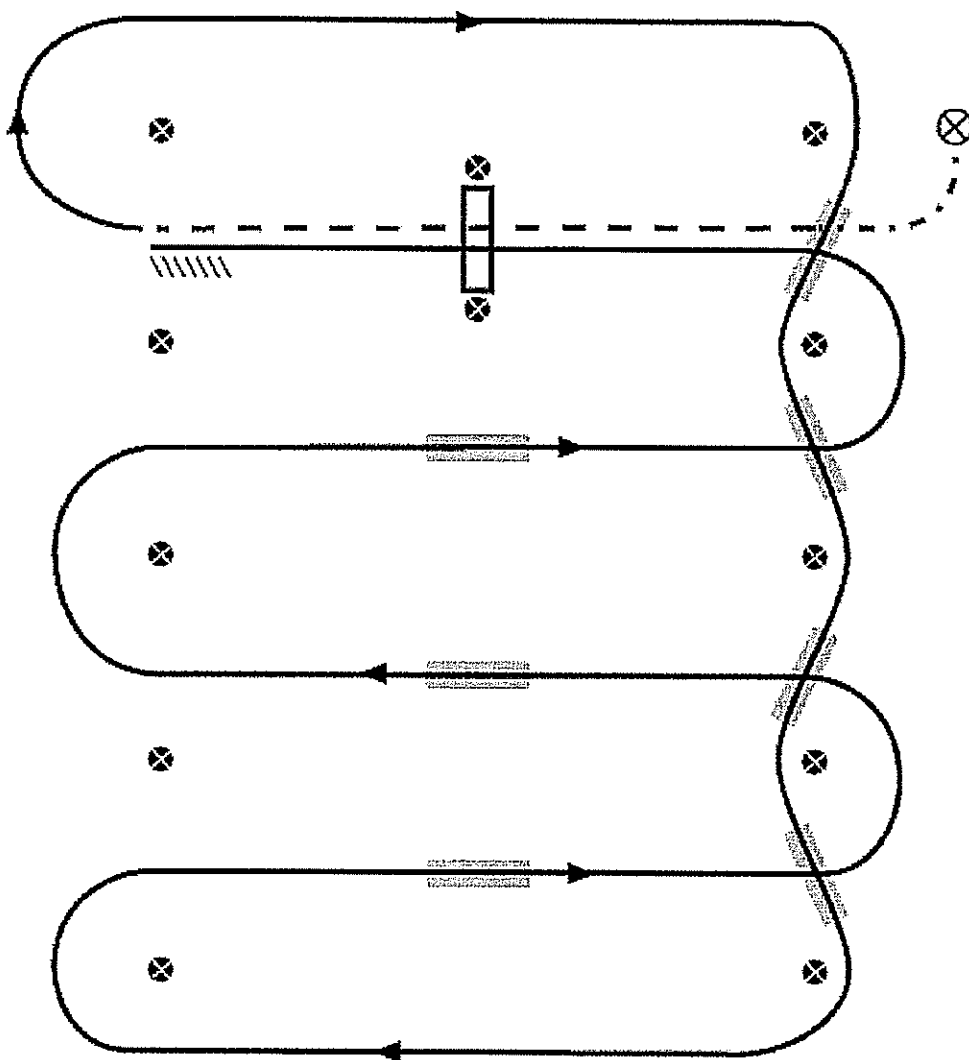

⊗ START CONE    WALK    - - - -    JOG    - - - -  
 LEAD CHANGING AREA    [Hatched Box]    LOPE    \_\_\_\_\_

1. Walk, transition to jog, jog over log
2. Transition to the lope, on the right lead
3. First line change
4. Second line change
5. Third line change
6. Fourth line change
7. First crossing change
8. Second crossing change
9. Third crossing change
10. Lope over log
11. Lope, Stop & back

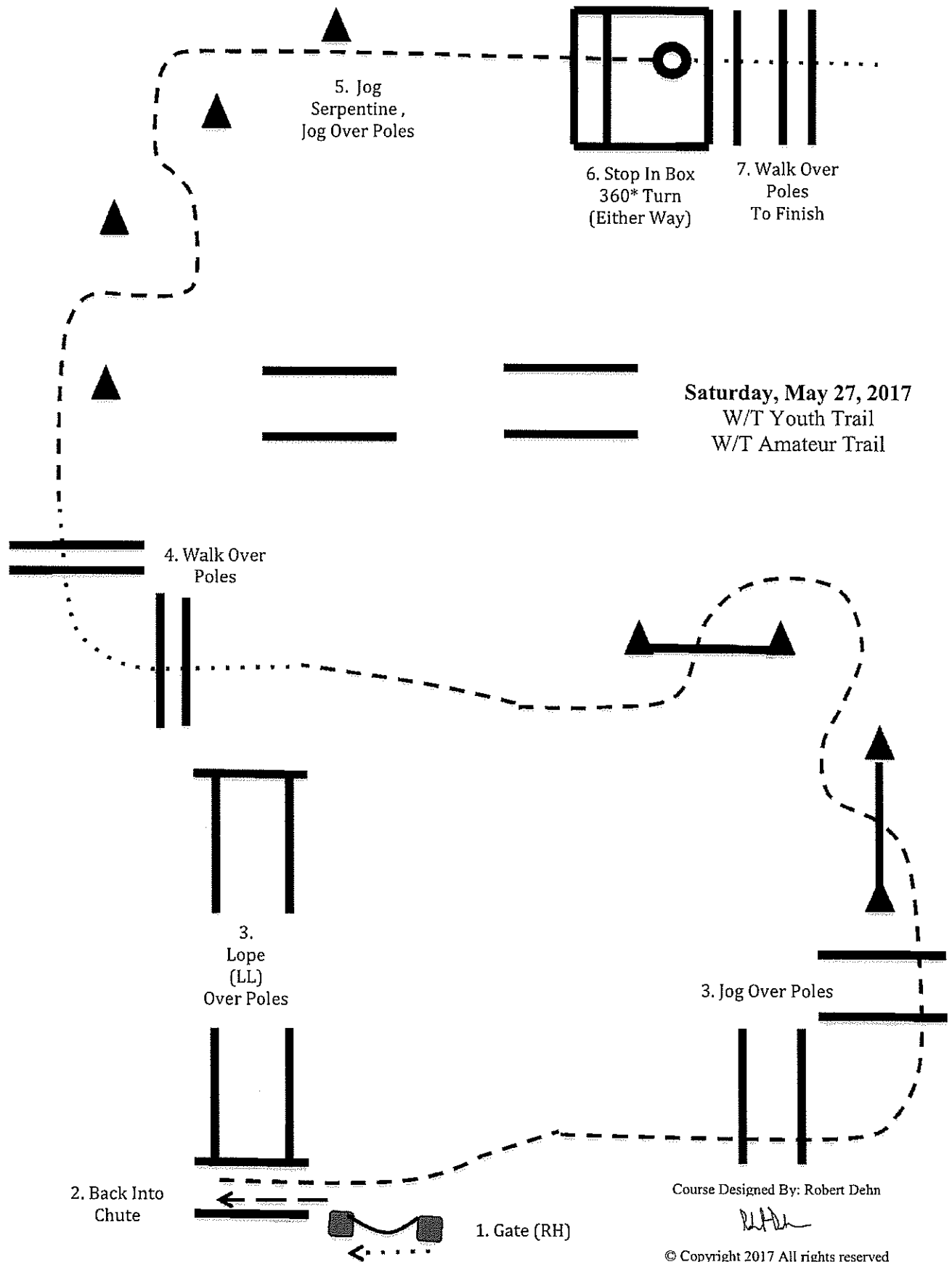

5. Jog Serpentine, Jog Over Poles

6. Stop In Box 360\* Turn (Either Way)

7. Walk Over Poles To Finish

Saturday, May 27, 2017  
W/T Youth Trail  
W/T Amateur Trail

4. Walk Over Poles

3. Lope (LL) Over Poles

3. Jog Over Poles

2. Back Into Chute

1. Gate (RH)

Course Designed By: Robert Dehn

© Copyright 2017 All rights reserved

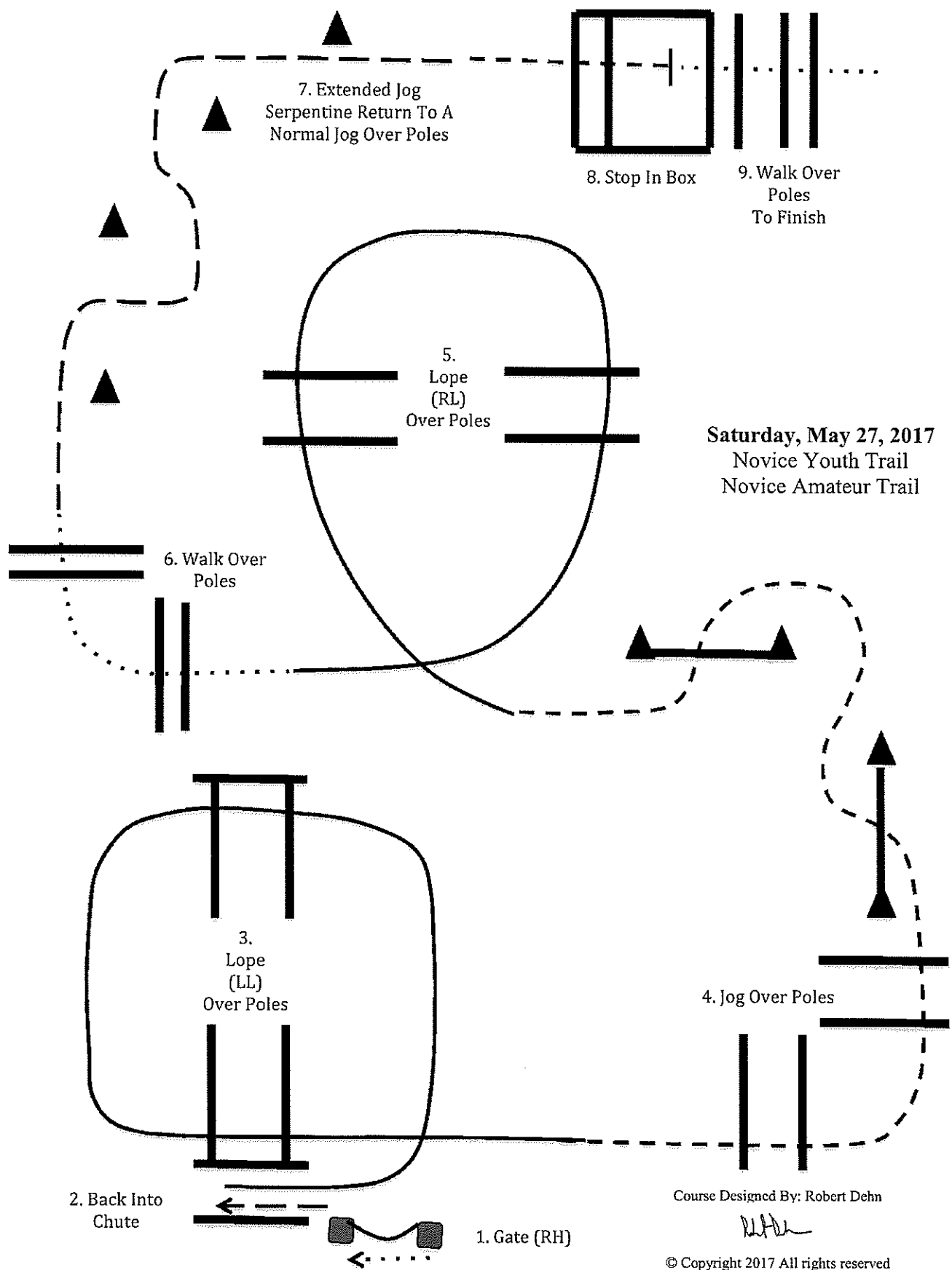

7. Extended Jog  
Serpentine Return To A  
Normal Jog Over Poles

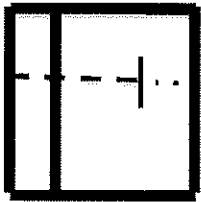

8. Stop In Box

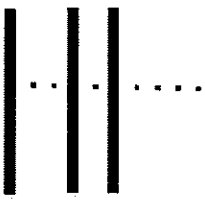

9. Walk Over  
Poles  
To Finish

5. Lope  
(RL)  
Over Poles

Saturday, May 27, 2017  
Novice Youth Trail  
Novice Amateur Trail

6. Walk Over  
Poles

3. Lope  
(LL)  
Over Poles

4. Jog Over Poles

2. Back Into  
Chute

1. Gate (RH)

Course Designed By: Robert Dehn

© Copyright 2017 All rights reserved

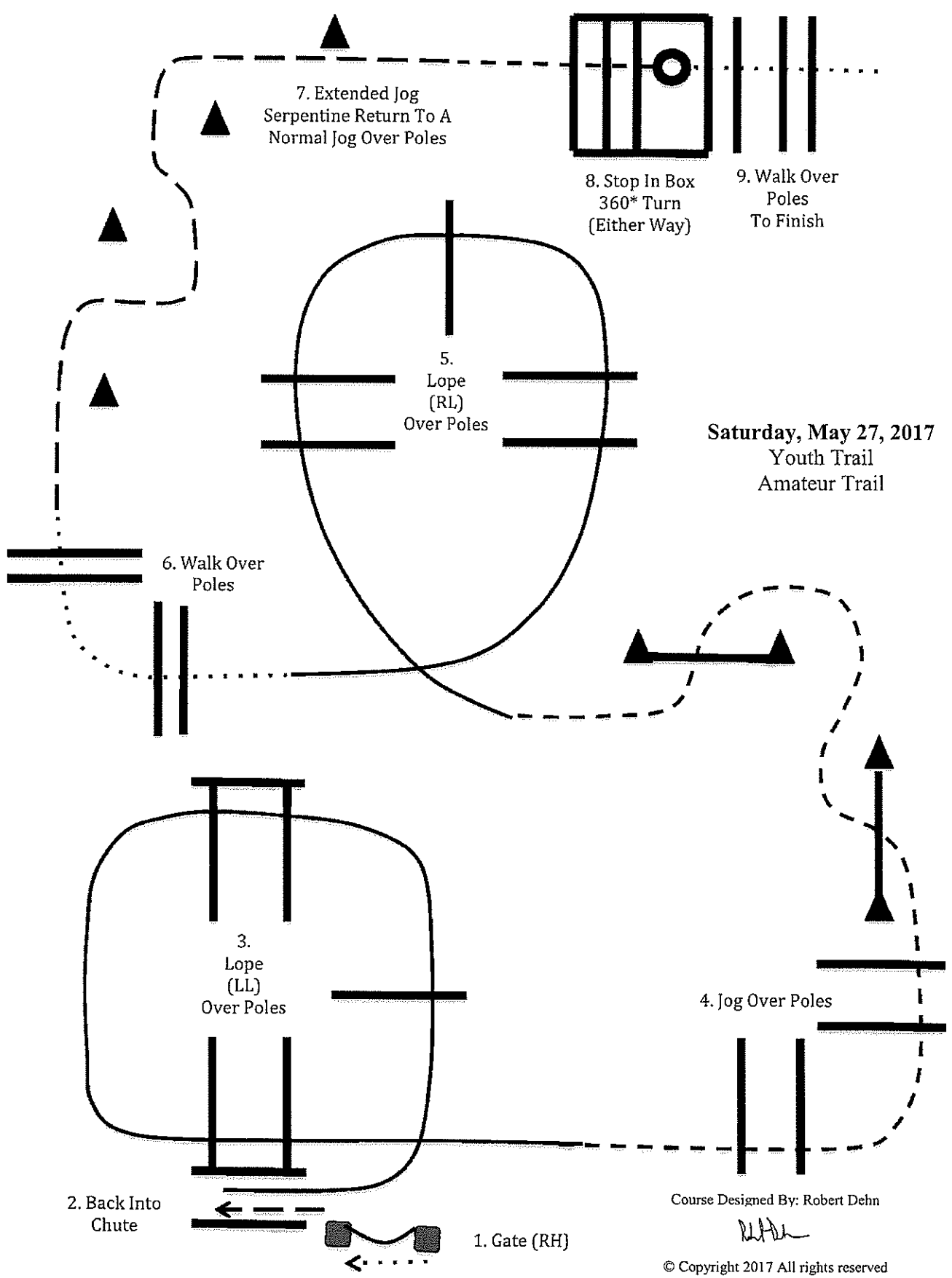

7. Extended Jog  
Serpentine Return To A  
Normal Jog Over Poles

8. Stop In Box  
360\* Turn  
(Either Way)

9. Walk Over  
Poles  
To Finish

5.  
Lope  
(RL)  
Over Poles

Saturday, May 27, 2017  
Youth Trail  
Amateur Trail

6. Walk Over  
Poles

3.  
Lope  
(LL)  
Over Poles

4. Jog Over Poles

2. Back Into  
Chute

1. Gate (RH)

Course Designed By: Robert Dehn

*RDH*

© Copyright 2017 All rights reserved



### Ranch Riding Pattern #3

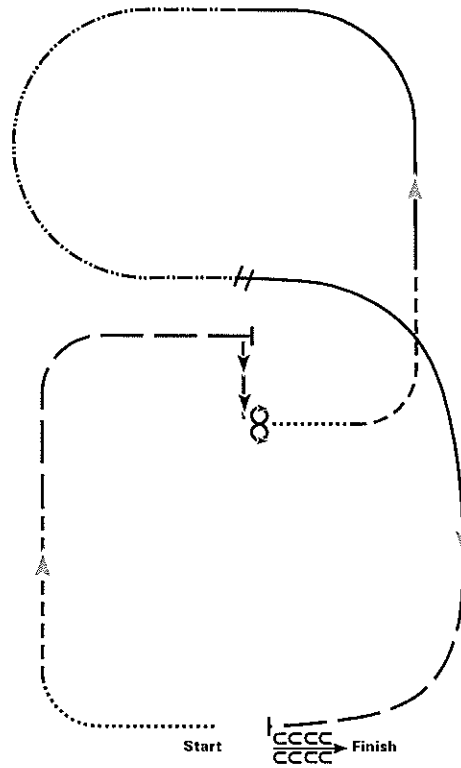

1. Walk to the left around corner of the arena
2. Trot
3. Extend alongside of the arena and around the corner to center
4. Stop, side pass right
5. 360 turn each direction (either way 1st)
6. Walk
7. Trot
8. Lope left lead
9. Extend the lope
10. Change leads (simple or flying)
11. Collect to the lope
12. Extend trot
13. Stop and back

## Reining (Youth & Amateur/ Pattern# 7)

W W W . H O R S E S H O W P A T T E R N S . C O M

W W W . H O R S E S H O W P A T T E R N S . C O M

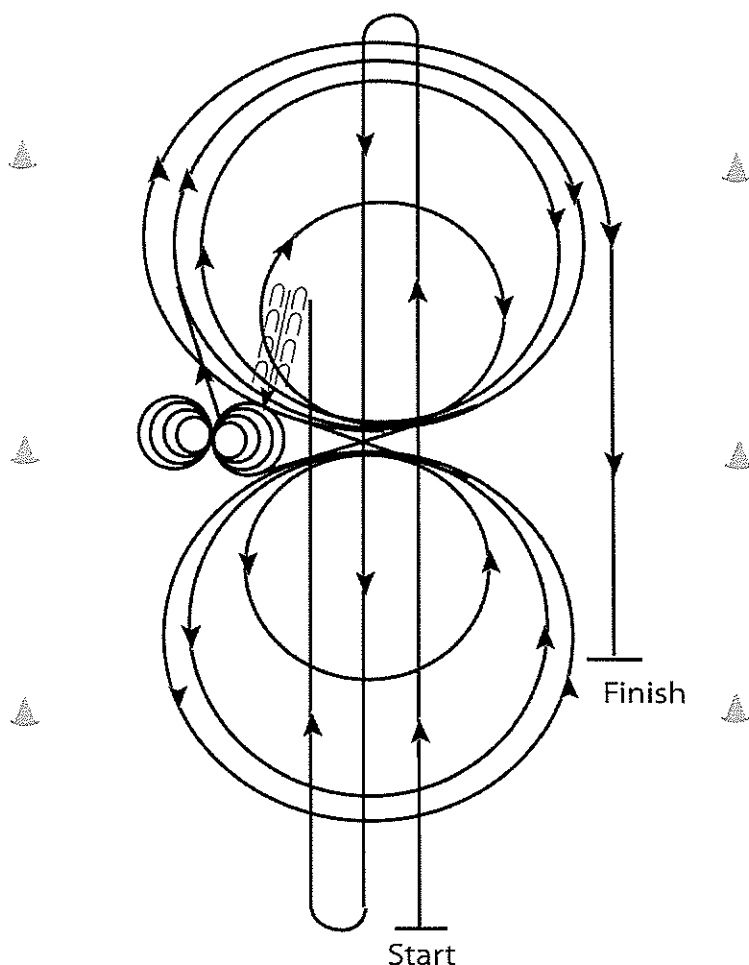

1. Run at speed to the far end of the arena past the end marker and do a left rollback – no hesitation.
2. Run to the opposite end of the arena past the end marker and do a right rollback – no hesitation.
3. Run past the center marker and do a sliding stop. Back up to the center of the arena at least ten feet (3m). Hesitate.
4. Complete four spins to the right.
5. Complete four and one-quarter spins to the left so that horse is facing left wall or fence. Hesitate.
6. Beginning on the right lead, complete three circles to the right: the first two circles large and fast; the third circle small and slow. Change leads at the center of the arena.
7. Complete three circles to the left: the first two circles large and fast; the third circle small and slow. Change leads at the center of the arena.
8. Begin a large fast circle to the right but do not close this circle. Run straight down the right side of the arena past the center marker and do a sliding stop at least twenty feet (6.09m) from the wall or fence. Hesitate to demonstrate completion of the pattern.  
Rider may dismount and drop bridle to the designated judge.

[R/NRHAP-7]

**Pattern Provided by:**

*The Judges*

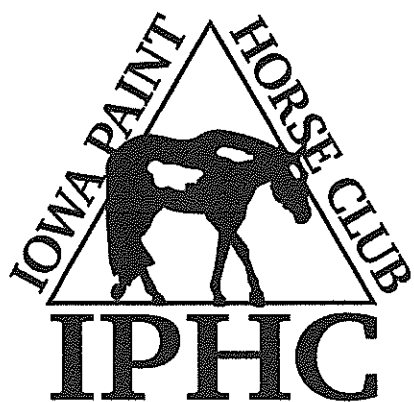

# SUNDAY'S PATTERNS

# Showmanship (Walk Trot Youth and Am)

Show Date:

W W W . H O R S E S H O W P A T T E R N S . C O M

W W W . H O R S E S H O W P A T T E R N S . C O M

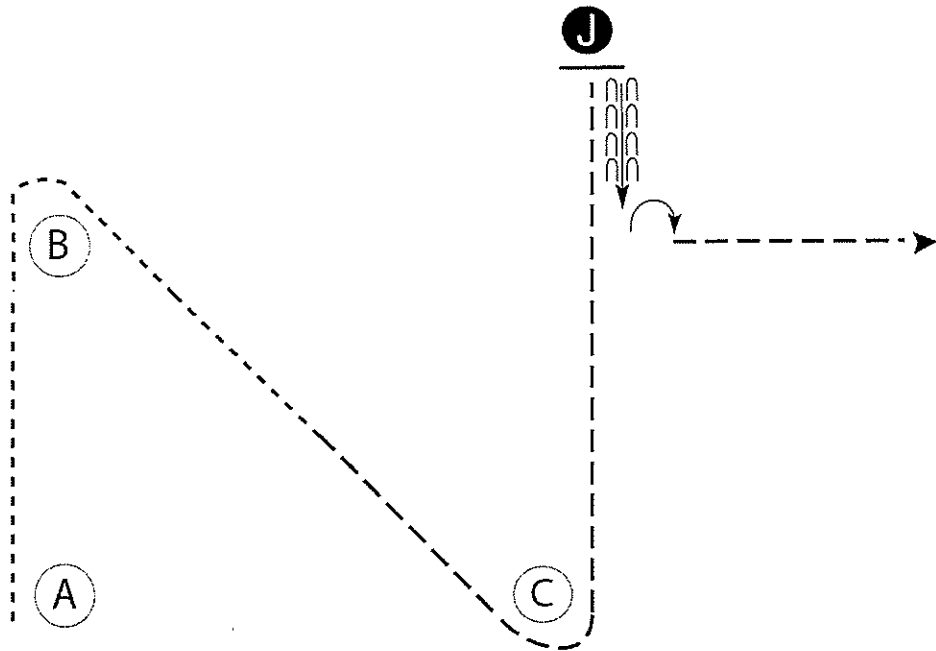

Be ready at A.

1. Walk to and around B.
2. Halfway to C, trot to and around C and straight to judge.
3. Stop and set up for inspection.
4. When dismissed, back one horse length.
5. Perform a 90 degree turn.
6. Trot straight away to finish.

Walk	-----
Trot	- - - - -
Back	←
Marker	⊙ B
Judge	● J

[S/WT-22]

Pattern Provided by:  
*Heather Young*

# Showmanship (All but Walk-Trot)

Show Date:

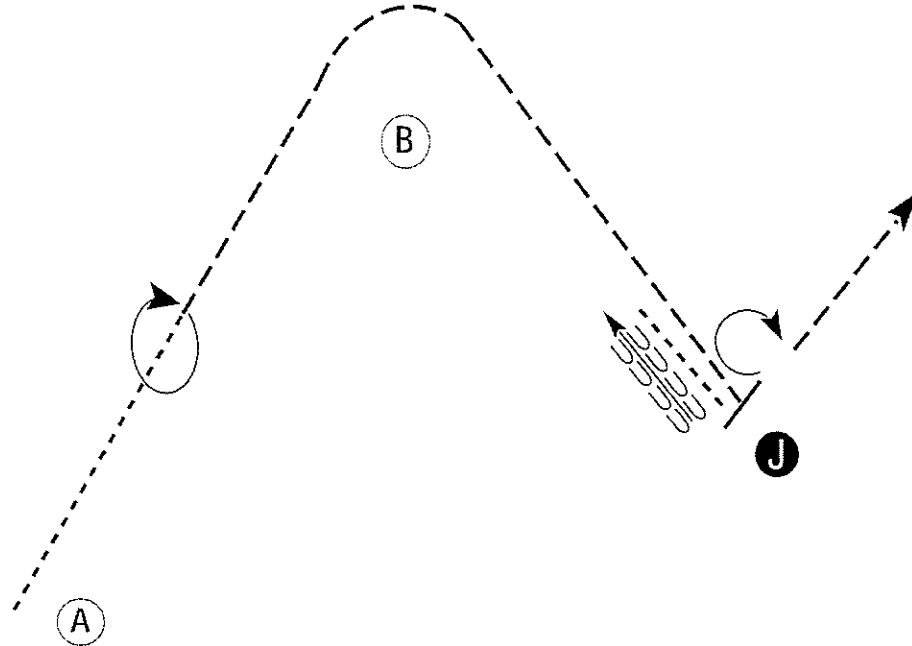

Be ready at A.

1. Walk halfway to B.
2. Stop and perform a 360 degree turn.
3. Trot around B to the Judge.
4. Stop and back approximately one horse length.
5. Walk to the Judge, stop and set up for inspection.
6. When dismissed, perform a 270 degree turn and trot straight away from the Judge.

Walk	-----
Trot	- - - - -
Back	←
Marker	ⓑ
Judge	ⓐ

Follow the instructions of your ring steward.

[S/3-34]

Pattern Provided by:  
*Heather Young*

# All Hunt Seat Equitation (Walk-Trot)

Show Date:

W W W . H O R S E S H O W P A T T E R N S . C O M

Be ready at A.

1. Walk until even with B.
2. Trot on the left diagonal to B.
3. Sitting trot from B to C.
4. Walk around C.
5. Trot on the right diagonal to B.
6. Stop and back approximately one horse length.
7. Perform a 180 degree turn to the right on the hindquarters and trot to exit.

Walk	-----
Trot	- - - - -
Extended Trot	— — — — —
Canter	—————
Leg Yield	
Lead Change	///
Back	←←←←←
Marker	Ⓚ
Sidepass	←- - - -→
Hand Gallop	— — — — —

W W W . H O R S E S H O W P A T T E R N S . C O M

[HSE/WT-38]

**Pattern Provided by:**  
*Heather Young*

# Hunt Seat Equitation (All but Walk-Trot)

Show Date:

www.HorseShowPatterns.com

www.HorseShowPatterns.com

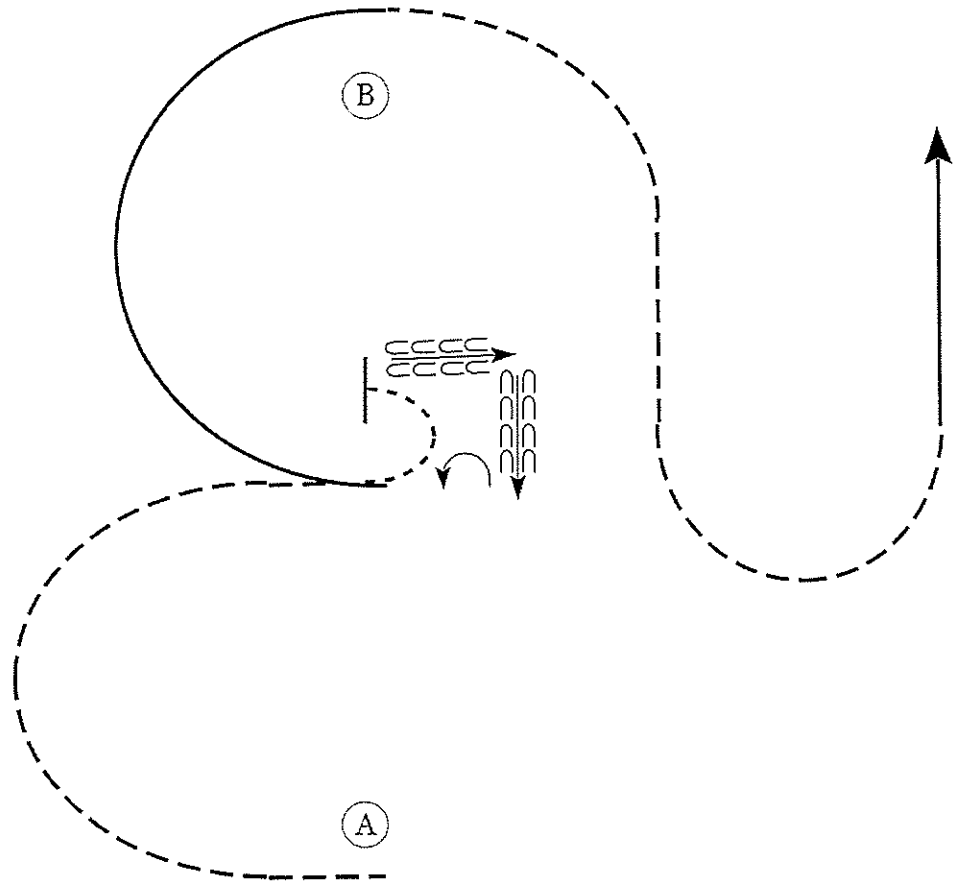

Be ready at A.

1. Posting trot to center of pattern.
2. Break to a walk and walk a small half circle.
3. Stop and back a square corner.
4. Perform a 1/4 turn on the forehand left.
5. Canter on the right lead to B.
6. Posting trot on the left diagonal to center of pattern. Change diagonals and continue posting trot in a half circle.
7. Left lead canter to exit.

Follow the instructions of your ring steward.

Walk	-----
Trot	- - - - -
Extended Trot	— — — — —
Canter	—————
Leg Yield	
Lead Change	— / —
Back	← ← ← ← ←
Marker	⊙ B
Sidepass	← - - - ←
Hand Gallop	———

[HSE/2-73]

**Pattern Provided by:**  
*Heather Young*

# Hunter Hack (All)

Show Date:

www.HorseShowPatterns.com

www.HorseShowPatterns.com

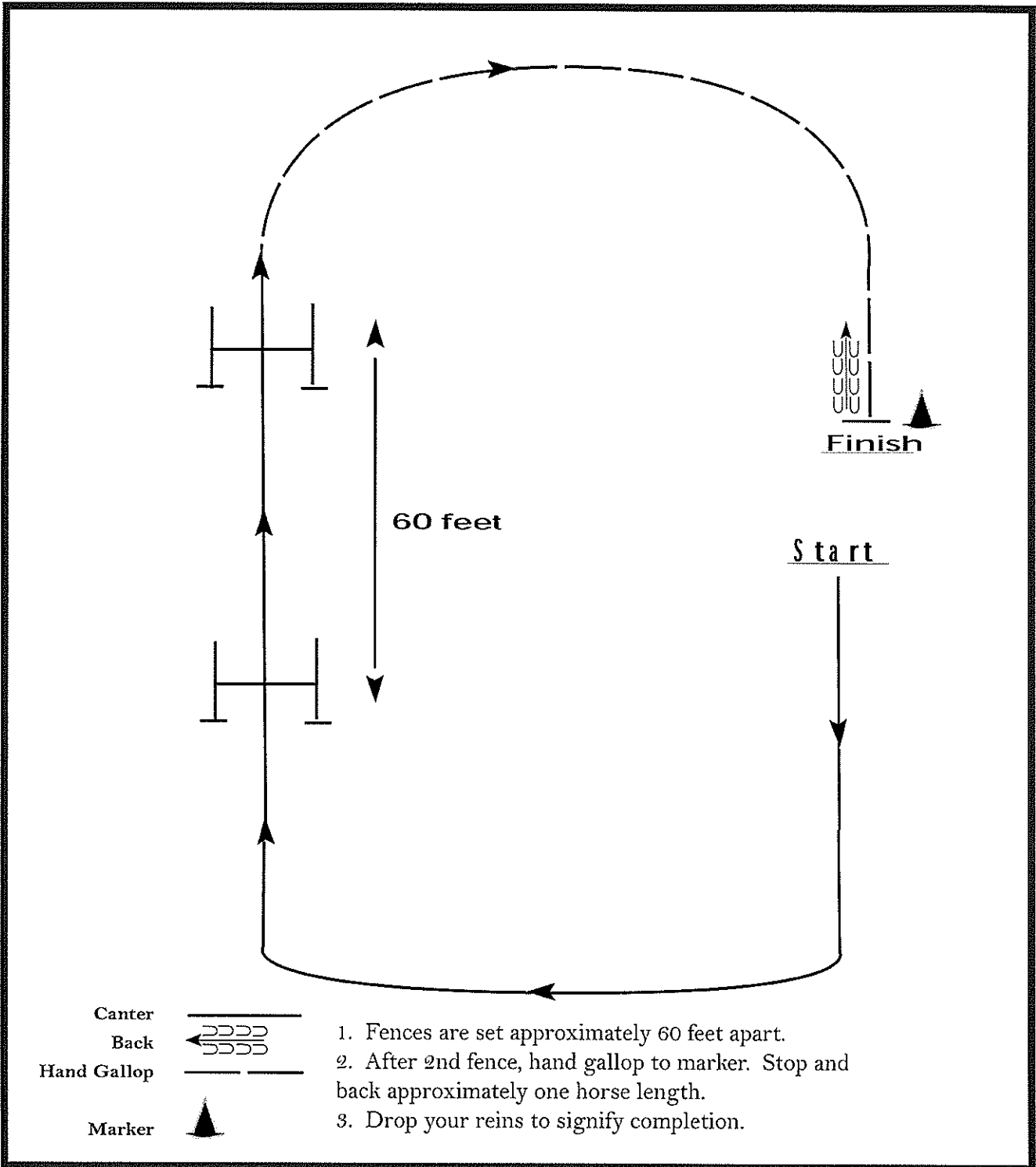

[HH/60-2]

Pattern Provided by:  
*Heather Young*



# Western Riding (All but Green)

Show Date:

W W W . H O R S E S H O W P A T T E R N S . C O M

W W W . H O R S E S H O W P A T T E R N S . C O M

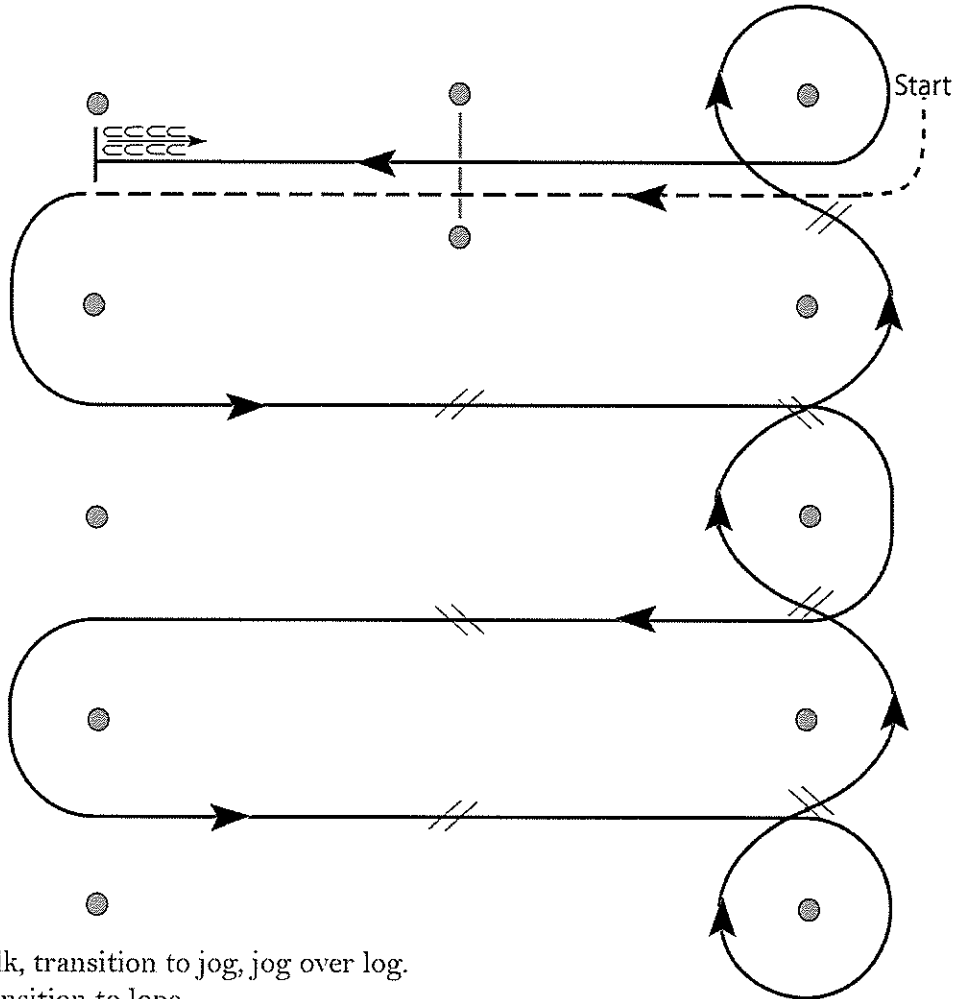

1. Walk, transition to jog, jog over log.
2. Transition to lope.
3. First crossing change.
4. Second crossing change.
5. Third crossing change.
6. Circle and first line change.
7. Second line change.
8. Third line change.
9. Fourth line change and circle.
10. Lope log.
11. Lope, stop and back.

[WR/OP-2]

Pattern Provided by:  
*Heather Young*

# Green Western Riding

Show Date:

www.HorseShowPatterns.com

www.HorseShowPatterns.com

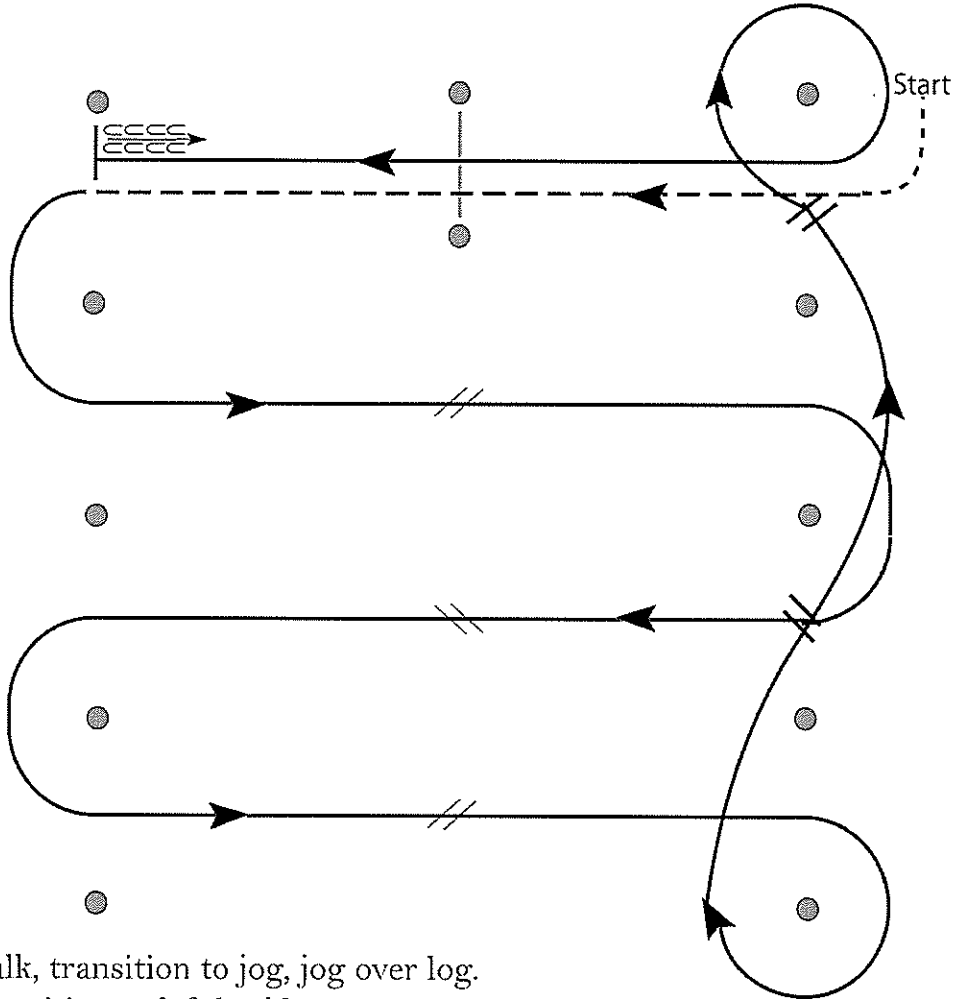

1. Walk, transition to jog, jog over log.
2. Transition to left lead lope.
3. First crossing change.
4. Second crossing change.
5. Third crossing change.
6. Circle and first line change.
7. Second line change and circle.
8. Lope log.
9. Stop and back.

[WR/GP-2]

Pattern Provided by:  
*Heather Young*

# Ranch Riding (All)

Show Date:

www.HorseShowPatterns.com

www.HorseShowPatterns.com

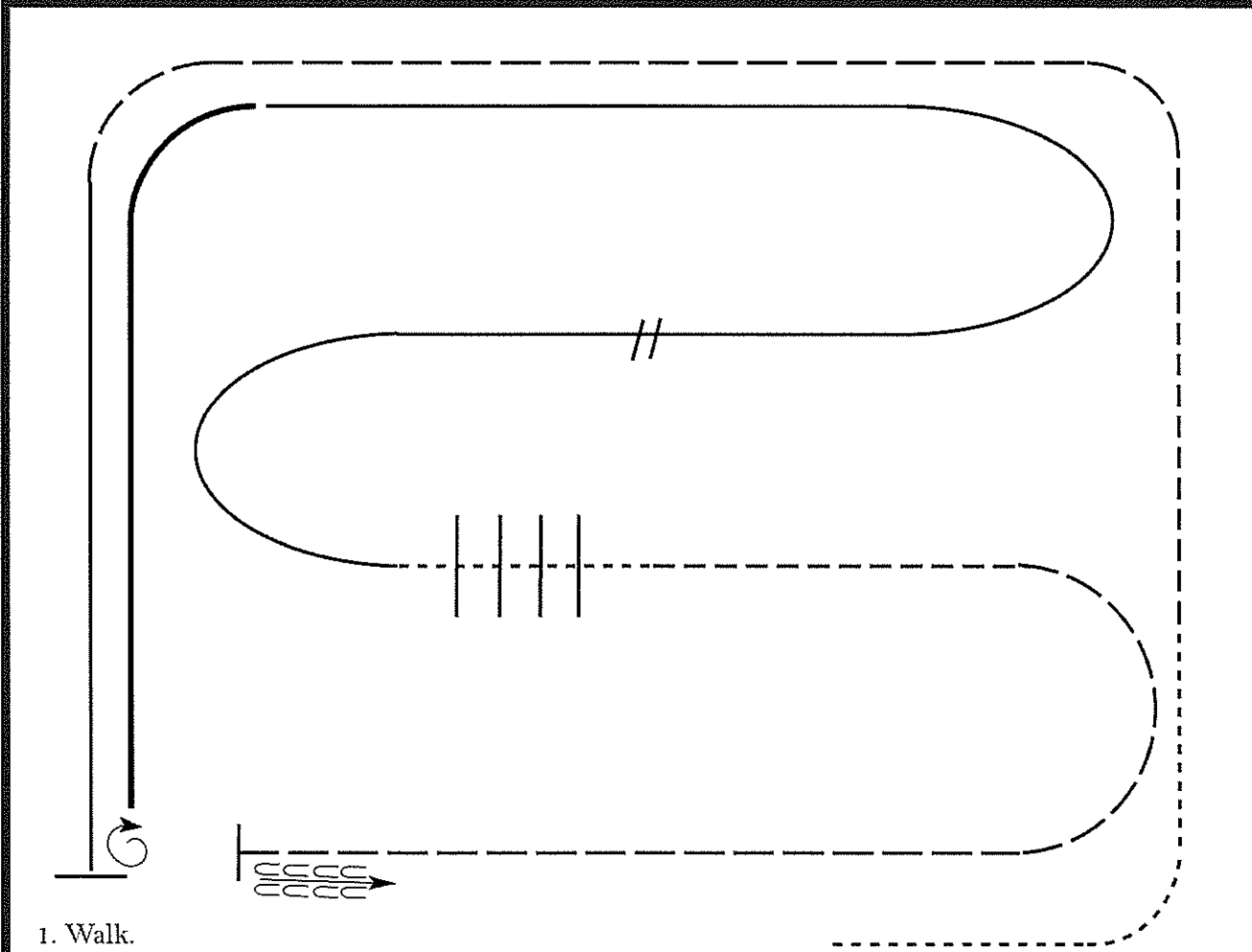

1. Walk.
2. Trot
3. Extended trot.
4. Left lead lope
5. Stop, 1 1/2 turn right
6. Extended lope
7. Collect to working lope-right lead
8. Change leads (simple or flying)
9. Walk
10. Walk over logs
11. Trot
12. Extended trot
13. Stop and back

Walk	-----
Jog	- - - - -
Extended Jog	_____
Lope	—————
Lead Change	
Back	
Marker	Ⓚ

[RR/2]

Pattern Provided by:  
*Heather Young*

# Reining (All)

Show Date:

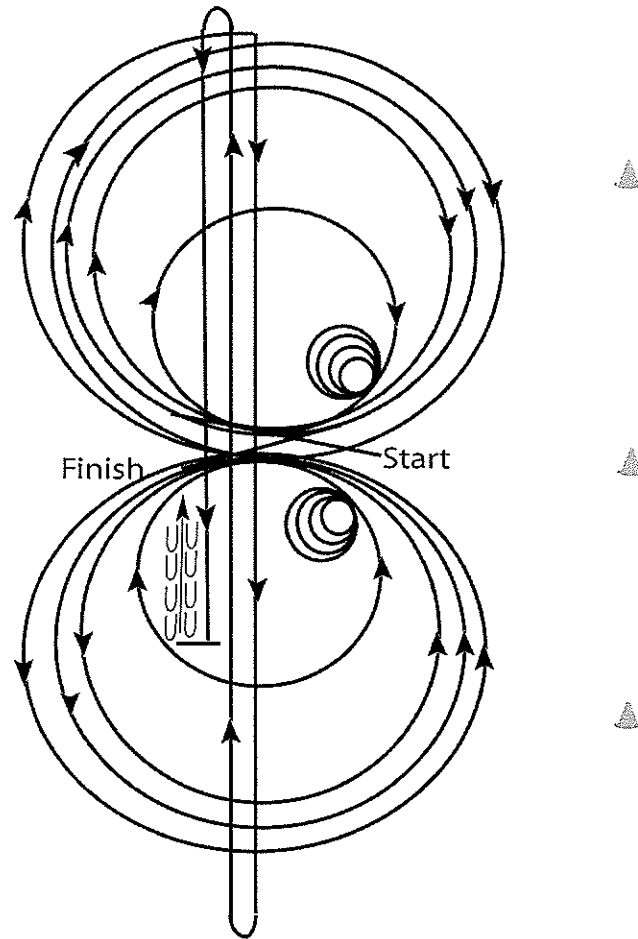

Horses may walk or trot to the center of the arena. Begin at the center of the arena facing the left wall or fence.

1. Beginning on the right lead, complete three circles to the right; the first two circles large and fast; the third circle small and slow. Stop at the center of the arena.
  2. Complete four spins to the right. Hesitate.
  3. Beginning on the left lead, complete three circles to the left; the first two circles large and fast; the third circle small and slow. Stop at the center of the arena.
  4. Complete four spins to the left. Hesitate.
  5. Beginning on the right lead, run a large first circle to the right, change leads at the center of the arena, run a large fast circle to the left, and change leads at the center of the arena.
  6. Continue around previous circle to the right. At the top of the circle, run down the middle to the far end of the arena past the end marker and do a right rollback - no hesitation.
  7. Run up the middle to the opposite end of the arena past the end marker and do a left rollback - no hesitation.
  8. Run past the center marker and do a sliding stop. Back up to the center of the arena or at least 10 feet (3m). Hesitate to demonstrate completion of the pattern.
- Rider may dismount and drop bridle to the designated judge.

[R/NRHAP-4]

Pattern Provided by:

*Heather Young*



# MONDAY'S PATTERNS

Monday, May 29, 2017  
 Yearling In Hand Trail  
 Walk Trot Youth Trail  
 Walk Trot Amateur Trail

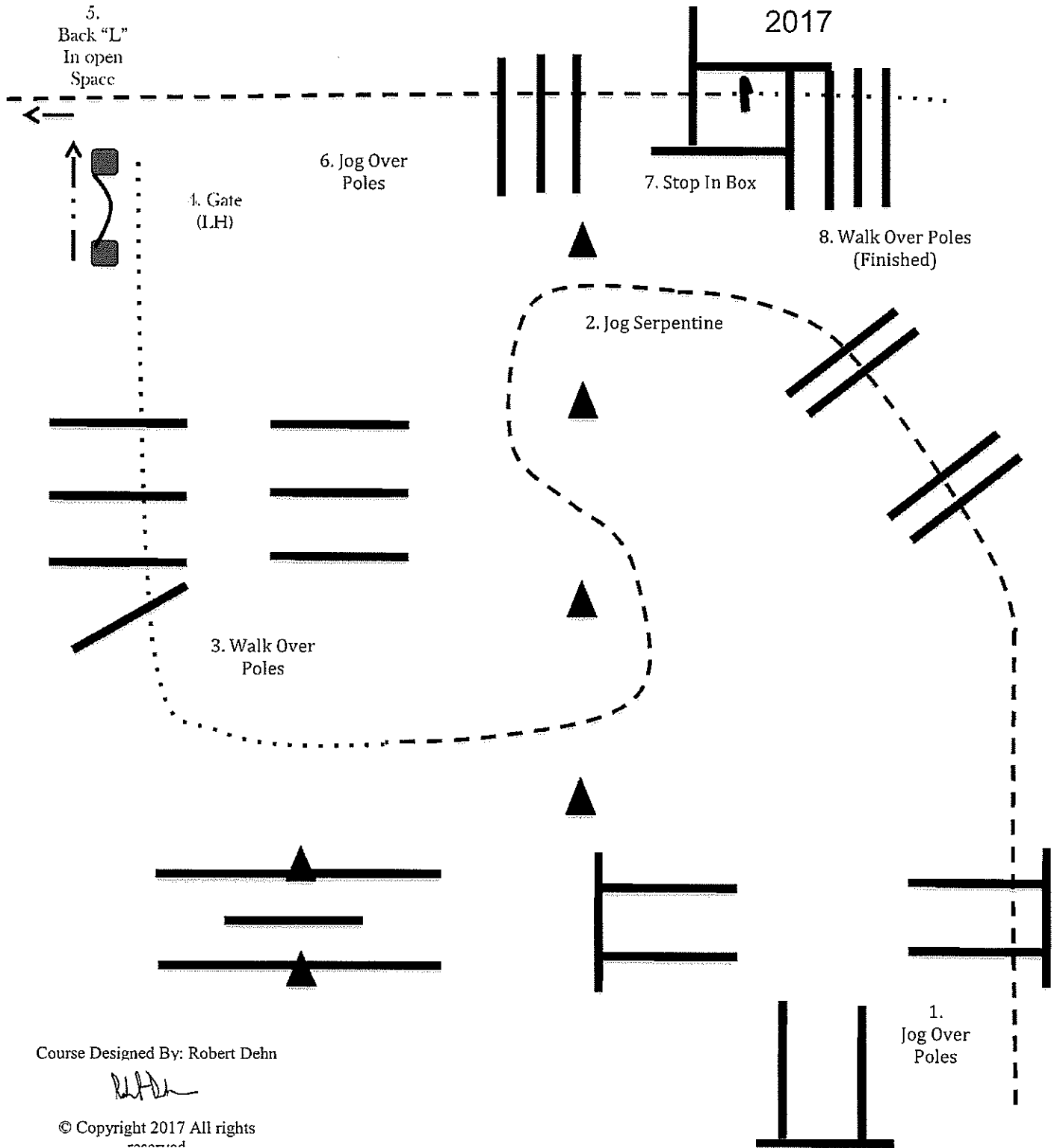

Course Designed By: Robert Dehn

*Robert Dehn*

© Copyright 2017 All rights reserved

Monday, May 29, 2017

Green Trail  
Novice Youth Trail  
Novice Amateur Trail

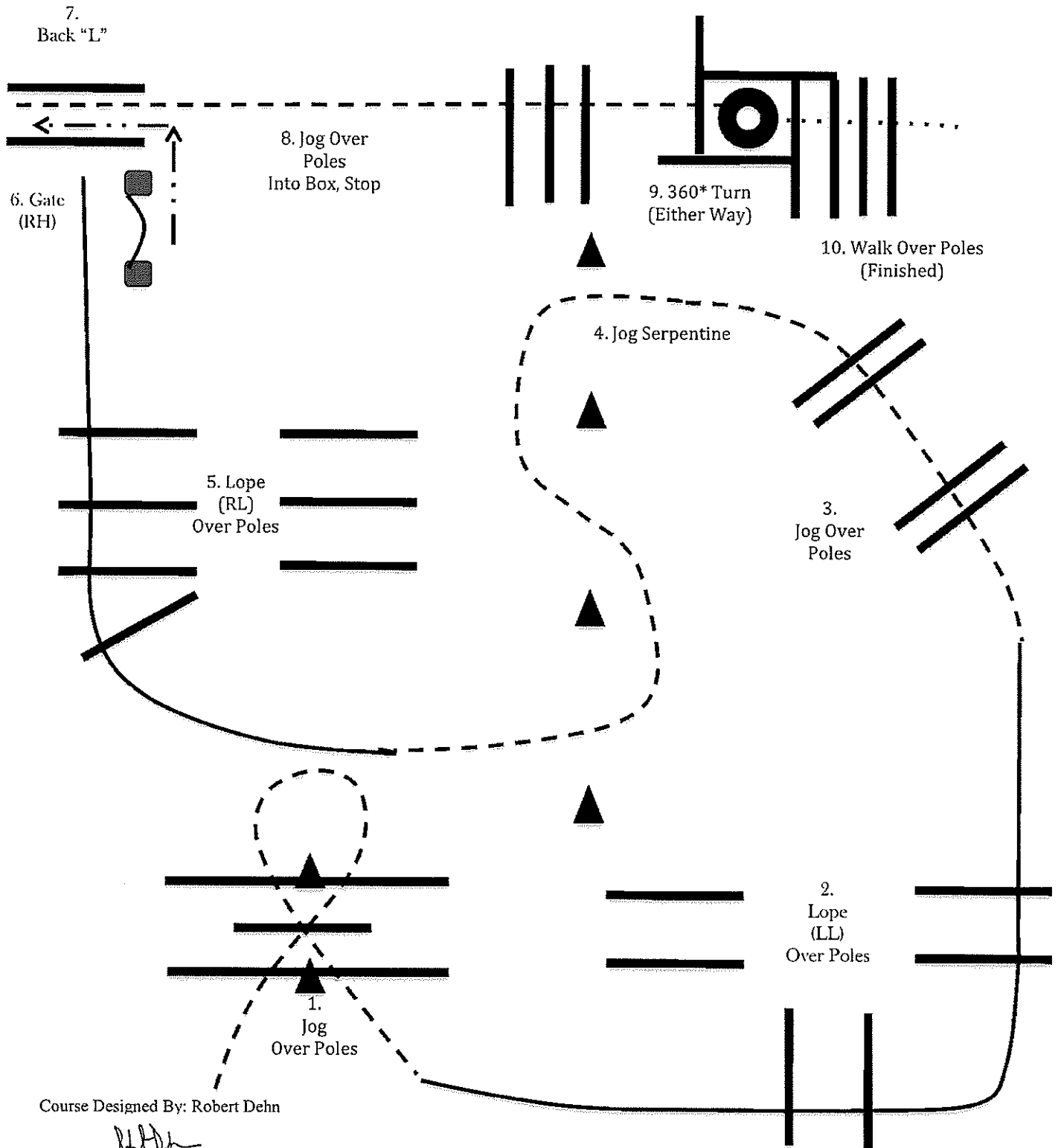

Course Designed By: Robert Dehn

© Copyright 2017 All rights reserved

Monday, May 29, 2017  
Youth Trail  
Amateur Trail  
Trail

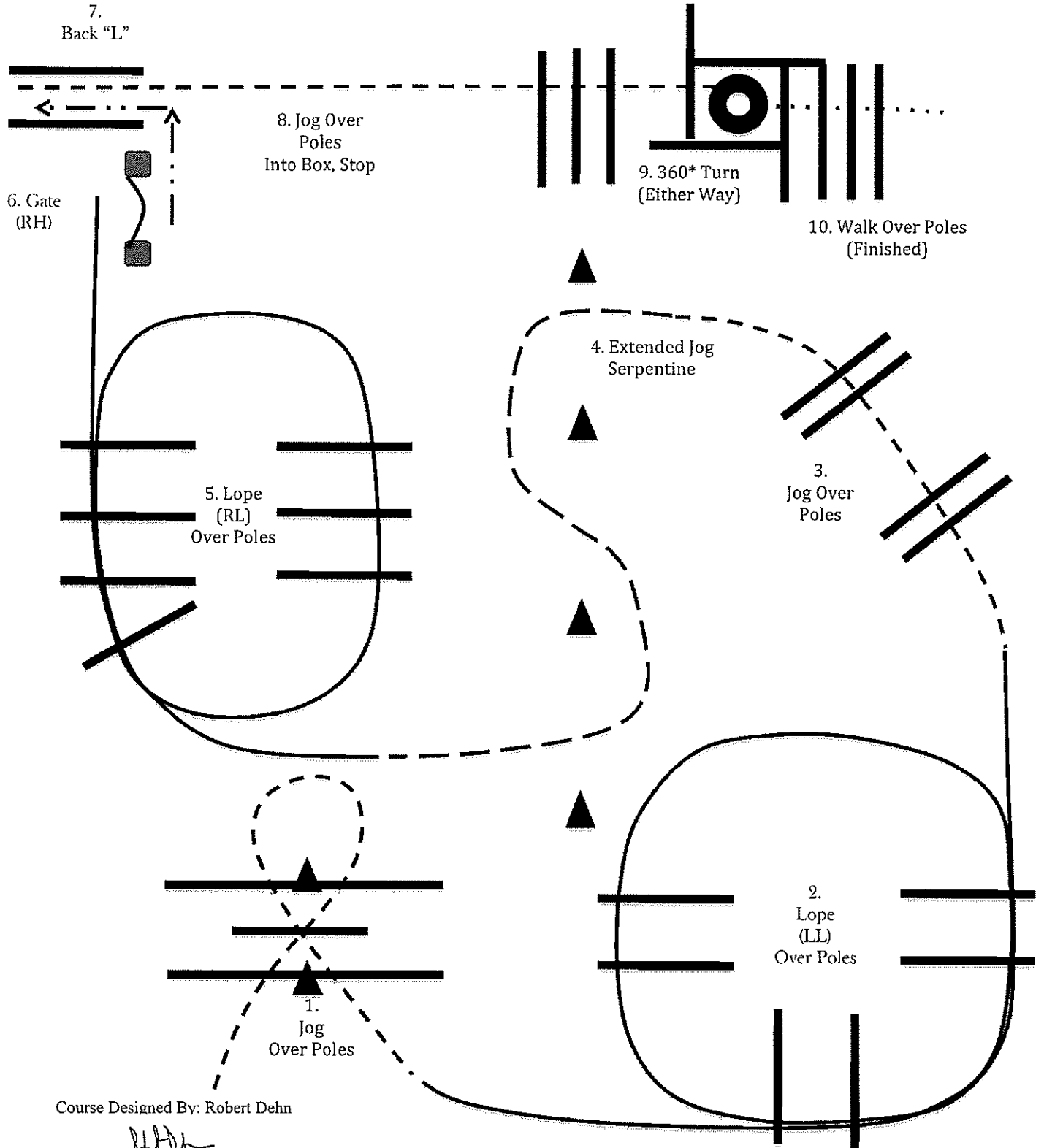

Course Designed By: Robert Dehn



# Western Horsemanship (Walk-Trot)

Show Date:

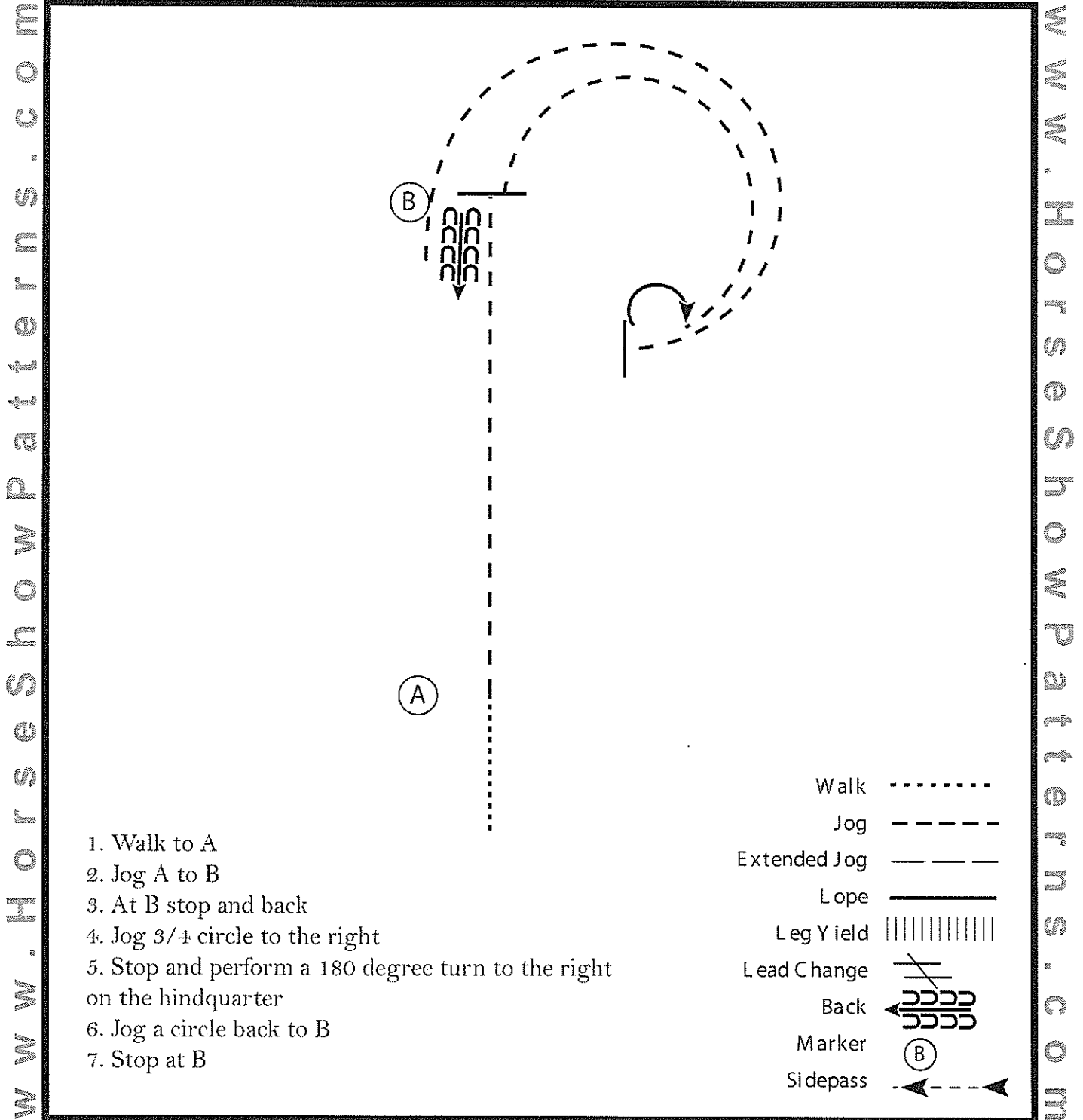

1. Walk to A
2. Jog A to B
3. At B stop and back
4. Jog  $3/4$  circle to the right
5. Stop and perform a 180 degree turn to the right on the hindquarter
6. Jog a circle back to B
7. Stop at B

- Walk .....
- Jog - - - - -
- Extended Jog - - - - -
- Lope \_\_\_\_\_
- Leg Yield |||||
- Lead Change / / / / /
- Back ← ← ← ← ←
- Marker (B)
- Sidepass → ← → ←

[WH/WT-12]

Pattern Provided by:  
*Heather Young*

# Western Horsemanship (All but Walk-Trot)

Show Date:

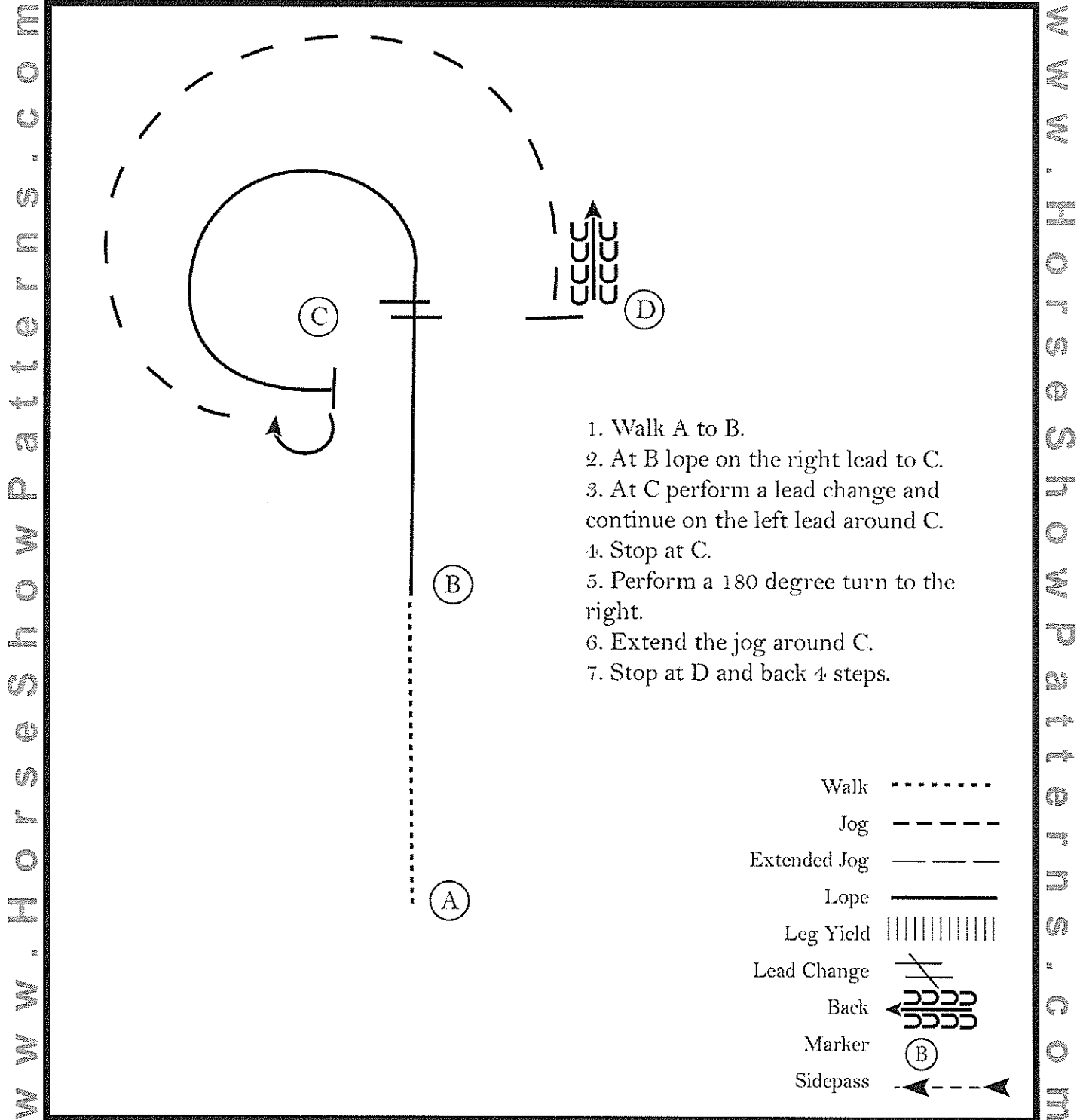

1. Walk A to B.
2. At B lope on the right lead to C.
3. At C perform a lead change and continue on the left lead around C.
4. Stop at C.
5. Perform a 180 degree turn to the right.
6. Extend the jog around C.
7. Stop at D and back 4 steps.

Walk	.....
Jog	- - - - -
Extended Jog	- - - - -
Lope	—————
Leg Yield	
Lead Change	———
Back	←←←←←
Marker	ⓑ
Sidepass	←——→

[WH/2-1]

Pattern Provided by:  
*Heather Young*